

INSTALLATION INSTRUCTIONS

SERIES BW3250 BLAST RESISTANT CURTAIN WALL

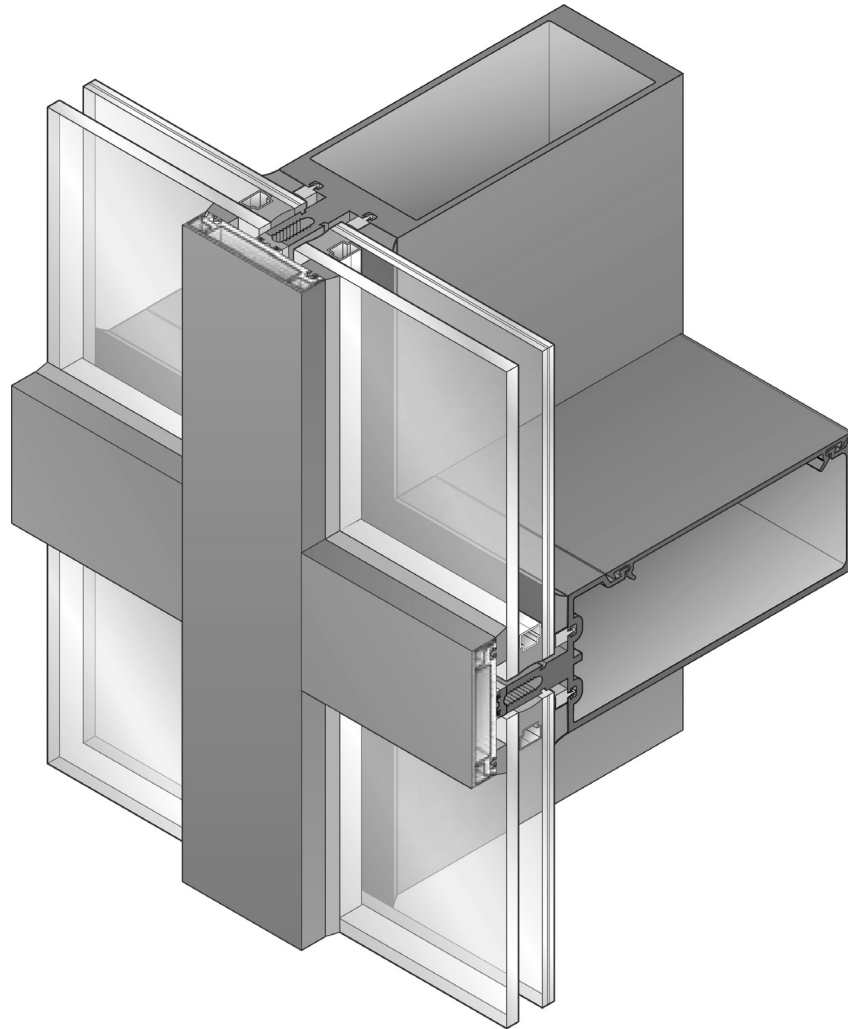

Phone: (800) 262-5151 • Fax: (866) 262-3299
crlaurence.com • usalum.com • crl-arch.com

HANDLING, STORAGE, AND PROTECTION OF ALUMINUM

The following precautions are recommended to protect the material against damage. Following these precautions will help ensure early acceptance of your products and workmanship.

A. HANDLE CAREFULLY.

All aluminum materials at the job site must be stored in a safe place, well removed from possible damage by other trades. Cardboard wrapped or paper interleaved materials must be kept dry.

B. CHECK ARRIVING MATERIALS.

Check for quantity counts and keep records of where various materials are stored.

C. KEEP MATERIALS AWAY FROM WATER, MUD, AND SPRAY.

Prevent cement, plaster, or other materials from damaging the finish.

D. PROTECT THE MATERIALS AFTER ERECTION.

Protect erected frame with polyethylene or canvas splatter screen. Cement, plaster, terrazzo, other alkaline solutions, and acid based materials used to clean masonry are harmful to the finish. ***If any of these materials come in contact with the aluminum, immediately remove with water and mild soap.***

The rapidly changing technology within the architectural aluminum products industry demands that U.S. Aluminum reserve the right to revise, discontinue or change any product line, specification or electronic media without prior written notice.

NOTE: Dimensions in parentheses () are millimeters unless otherwise noted.

GENERAL INSTALLATION NOTES

Recommended guidelines for all installations:

- 1. REVIEW CONTRACT DOCUMENTS.** Check shop drawings, installation instructions, architectural drawings, and shipping lists to become thoroughly familiar with the project. The shop drawings take precedence and include specific details for the project. Note any **field verified** notes on the shop drawings prior to installing. The installation instructions are of a general nature and cover most conditions.
- 2. INSTALLATION.** All materials are to be installed plumb, level, square, and true.
- 3. BENCH MARKS.** All work should start from bench marks and/or column lines as established by the architectural drawings and the general contractor with guaranteed accuracy. Working from these datum points and lines determine:
 - a) The plane of the wall in reference to offset lines provided on each floor.
 - b) The finish floor lines in reference to bench marks on the outer building columns.
 - c) Mullion spacing from both ends of masonry opening to prevent dimensional build-up of daylight opening.
- 4. STEEL ANCHORS.** Steel anchors that weld to steel structure are normally line set before mullions are hung. Outstanding leg of anchors must be at 90 degrees to offset lines. Mullion space should be held to $\pm 1/32"$ (0.8). Anchor clips vary per job conditions. Follow approved shop drawings for size and location of clips.
- 5. FIELD WELDING.** All field welding must be adequately shielded to avoid any splatter on glass or aluminum. Results will be unsightly and/or structurally unsound. Advise general contractor and other trades accordingly. All field welds of steel anchors must receive touch-up paint (zinc chromate) to avoid rust.
- 6. SURROUNDING CONDITIONS.** Make certain that construction which will receive your materials is in accordance with the contract documents. If not, notify the general contractor in writing and resolve differences before proceeding with work.
- 7. ISOLATION OF ALUMINUM.** Aluminum to be placed in direct contact with uncured masonry or incompatible materials should be isolated with a heavy coat of zinc chromate or bituminous paint.
- 8. SEALANTS.** Sealants must be compatible with all materials with which they have contact, including other sealant surfaces. Consult with sealant manufacturer for recommendations relative to joint size, shelf life, compatibility, cleaning, priming, tooling, adhesion, etc. It is the responsibility of the **Glazing Contractor** to submit a statement from the sealant manufacturer indicating that glass and glazing materials have been tested for compatibility and adhesion with glazing sealants, and interpreting test results relative to material performance, including recommendations for primers and substrate preparation required to obtain adhesion. The chemical compatibility of all glazing materials and framing sealants with each other and with like materials used in glass fabrication must be established. **This is required on every project.**
- 9. FASTENING.** Within the body of these instructions "fastening" means any method of securing one part to another or to adjacent materials. Only those fasteners used within the system are specified in these instructions. Due to the varying perimeter conditions and performance requirements, perimeter and anchor fasteners are not specified in these instructions. For perimeter and anchor fasteners refer to the shop drawings or consult the fastener supplier.
- 10. BUILDING CODES.** Due to the diversity in state/provincial, local, and federal laws and codes that govern the design and application of architectural products, it is the responsibility of the individual architect, owner, and installer to assure that products selected for use on projects comply with all the applicable building codes and laws. U.S. Aluminum exercises no control over the use or application of its products, glazing materials, and operating hardware, and assumes no responsibility thereof.
- 11. EXPANSION JOINTS.** Expansion joints and perimeter seals shown in these instructions and in the shop drawings are shown at normal size. Actual dimensions may vary due to perimeter conditions and/or difference in metal temperature between the time of fabrication and the time of installation. Gaps between expansion members should be based on temperature at time of installation.
- 12. WATER HOSE TEST.** As soon as representative amount of the wall has been glazed (500 square feet or 46.5 m²) a water hose test should be conducted in accordance with AAMA 501.2 specifications to check the installation. On all jobs the hose test should be repeated every 500 square feet (46.5 m²) during the glazing operation.
- 13. COORDINATION WITH OTHER TRADES.** Coordinate with the general contractor any sequence with other trades which offset curtain wall installation (i.e. fire proofing, back-up walls, partitions, ceilings, mechanical ducts, converters, etc.).
- 14. CARE AND MAINTENANCE.** Final cleaning of exposed aluminum surfaces should be done in accordance with AAMA 609.1 for anodized aluminum and 610.1 for painted aluminum.
- 15. JOB SITE ESSENTIALS.** See pages 24.

SITE PREPARATION

BEFORE INSTALLATION

1. Review and measure the opening.
2. Verify rough window opening size 1/2" (12.7) clearance in both width and height to the window. Verify framing is plumb, straight, and true around window opening. Measure opening at each end and at center vertically and horizontally. Make corrections to openings as required. Measure opening diagonally to check squareness. Chip concrete high points to flush and rounded corners to square.

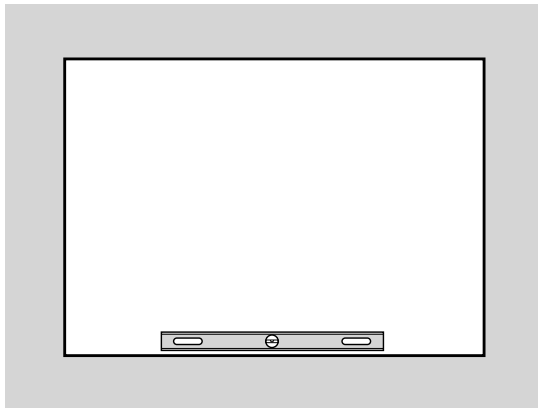

LEVEL

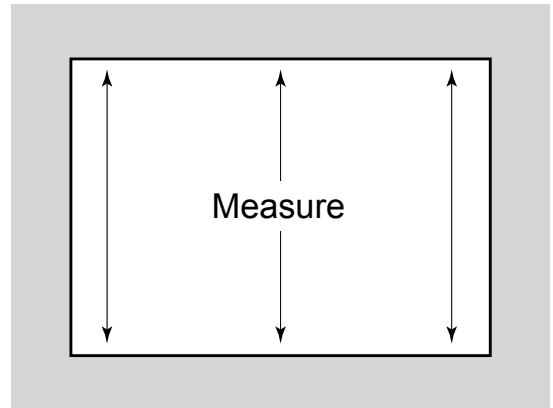

VERTICAL DIMENSION

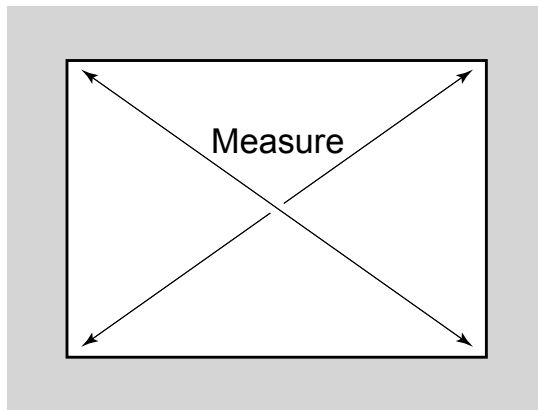

SQUARE

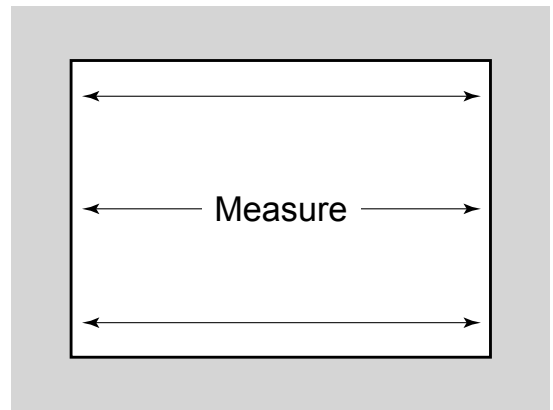

HORIZONTAL DIMENSION

FABRICATION

FRAME CUTTING

1. Cut members to size:

Vertical Members	Rough Opening (R.O.) Minus top and bottom clearances = Frame Height (F.H.).
Vertical Pressure Bars	F.H. Minus 1/4" (6.4)
Vertical Face Caps	F.H. Minus 1/32" (.8)
Horizontal Members	Day Light Opening (D.L.O.) Plus 0"
	(Cutting tolerances must not exceed D.L.O. dimension.)
Horizontal Pressure Bars	D.L.O. Minus 1/4" (6.4)
Horizontal Face Caps	D.L.O. Minus 1/32" (.8)

NOTE: The vertical cut lengths shown above are for non-spliced conditions. For spliced vertical member cut lengths refer to approved shop drawings. See **DETAIL V** on page 15.

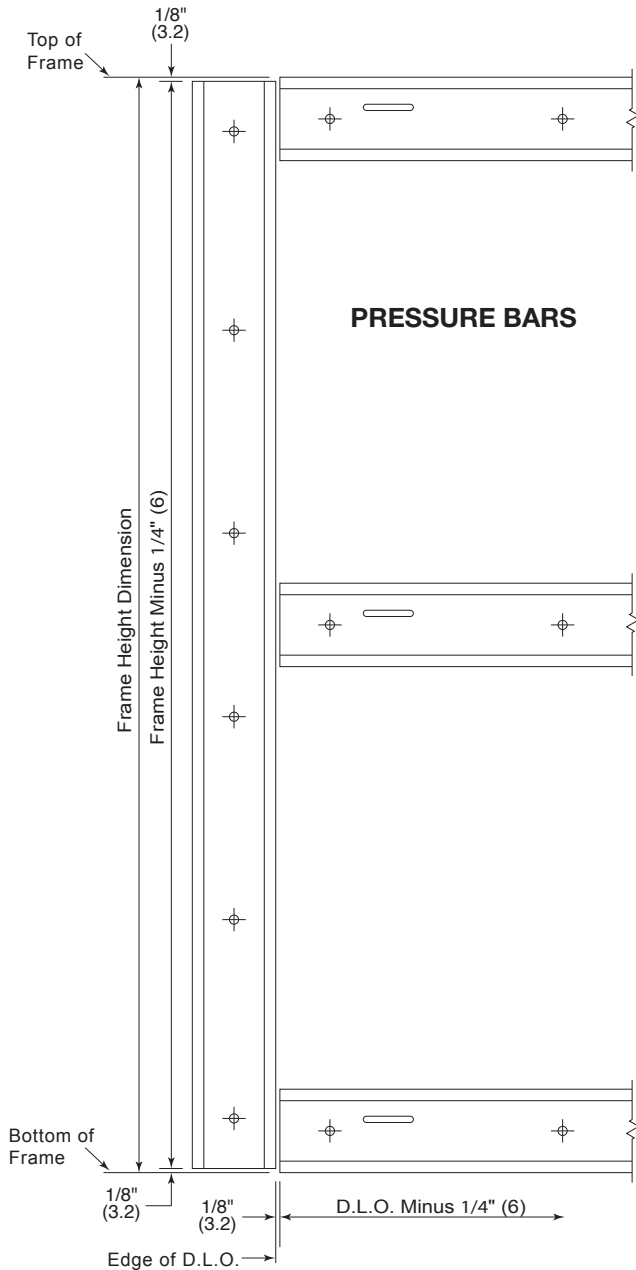

DETAIL A

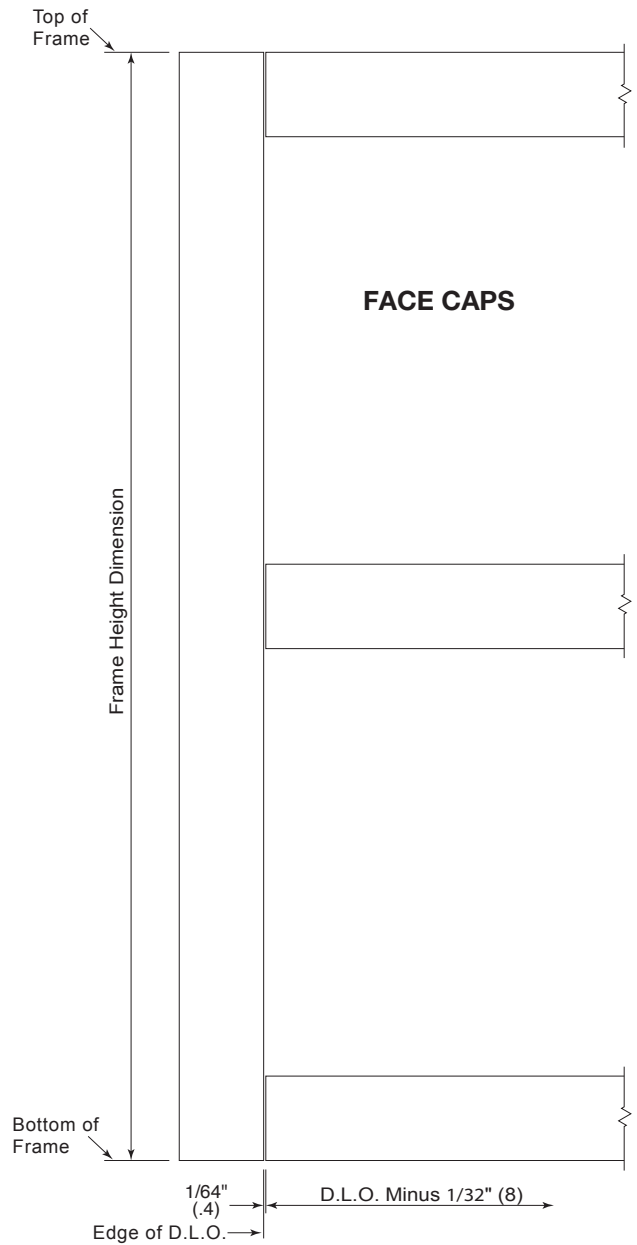

DETAIL B

NOT TO SCALE

FABRICATION

FABRICATE FOR SHEAR BLOCK

2. Mark on verticals the top of intermediate horizontal member locations. Align drill guide with mark as shown in **DETAIL C** and drill holes for shear blocks. Flush drill guide with top of vertical for head and bottom for sill. The drill guide locates pilot holes that must be enlarged to 11/32" (8.7) diameter or 21/32" (16.7) diameter as indicated in **DETAIL C** below for required load.

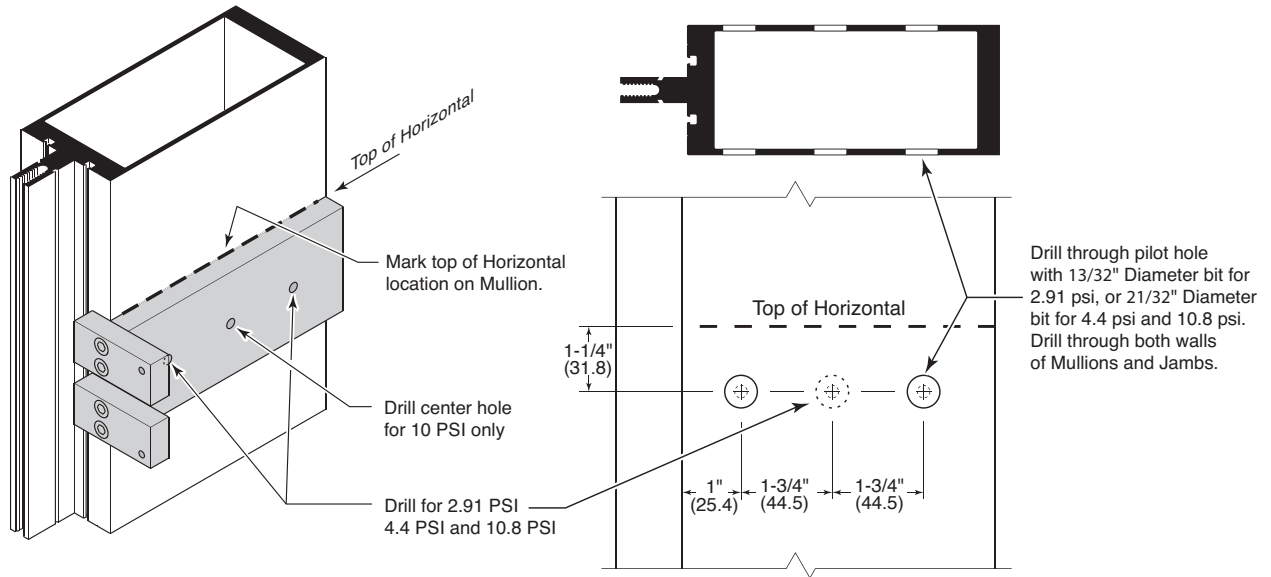

DETAIL C

3. Fabricate ends of horizontal members for shear block pick-up screws. See **DETAIL D** for drill usage.

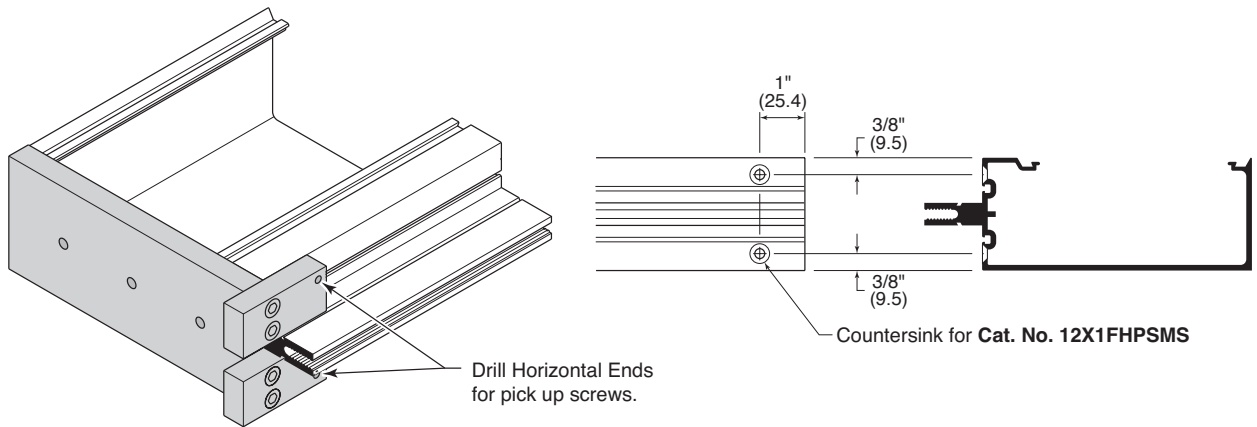

DETAIL D

4. Notch head and sill ends as shown in **DETAIL E** where head or sill caulk joint clearances are less than the typical 3/4" (19.5).

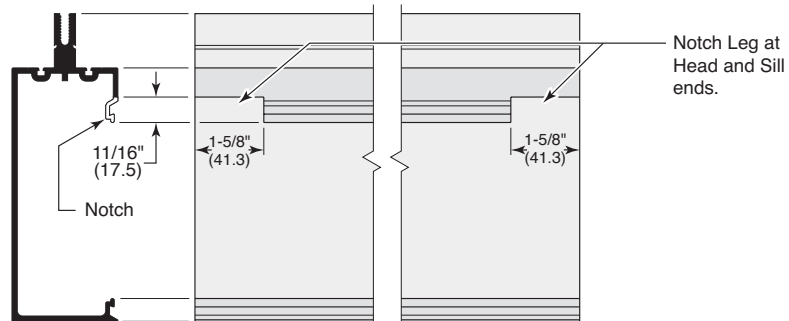

DETAIL E

NOT TO SCALE

FABRICATION

FABRICATE FOR CORNER SHEAR BLOCK

5. Fabricate corner mullion for tapping blocks and shear blocks as shown in **DETAIL F**.

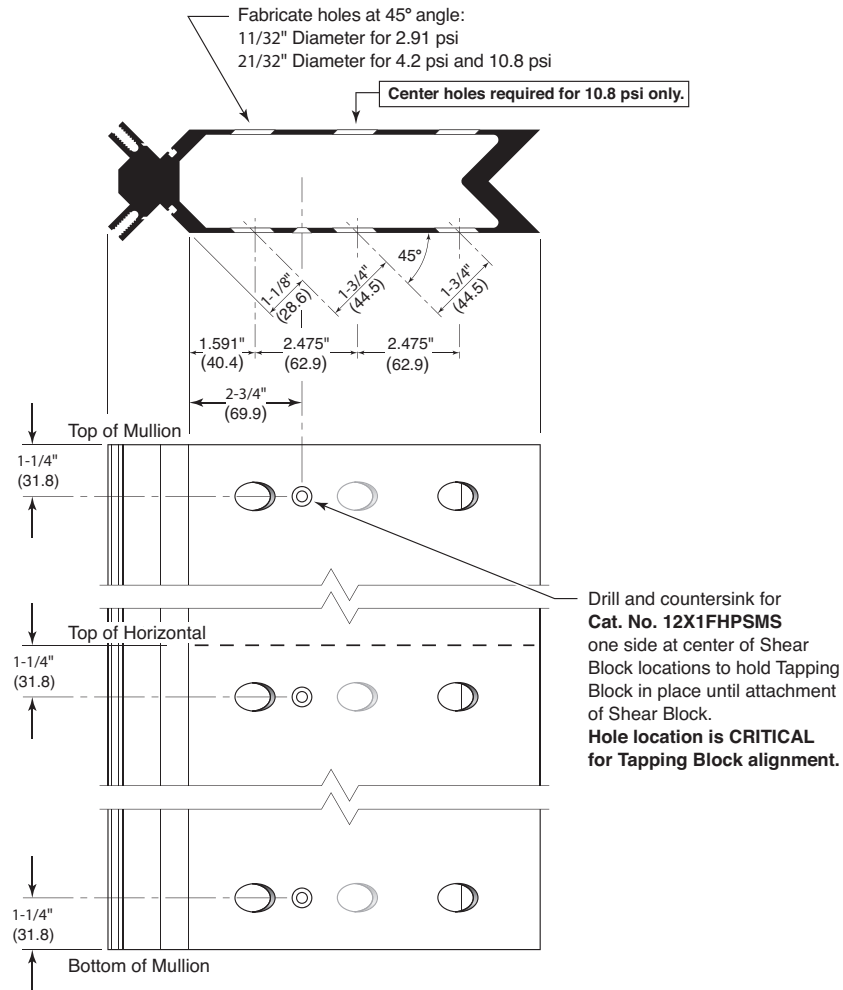

DETAIL F

6. Drill .182" diameter hole in tapping block to align with countersunk hole prep in corner mullion. **See DETAIL G.**

7. Slide tapping blocks into corner mullion centering on head, sill, and intermediate horizontal locations. Use (1) 12 X 1" FHP SMS (**Cat. No. 12X1FHPSMS**) to secure in place.

NOTE: Check alignment of tapping block and mullion holes for shear block bolt engagement.

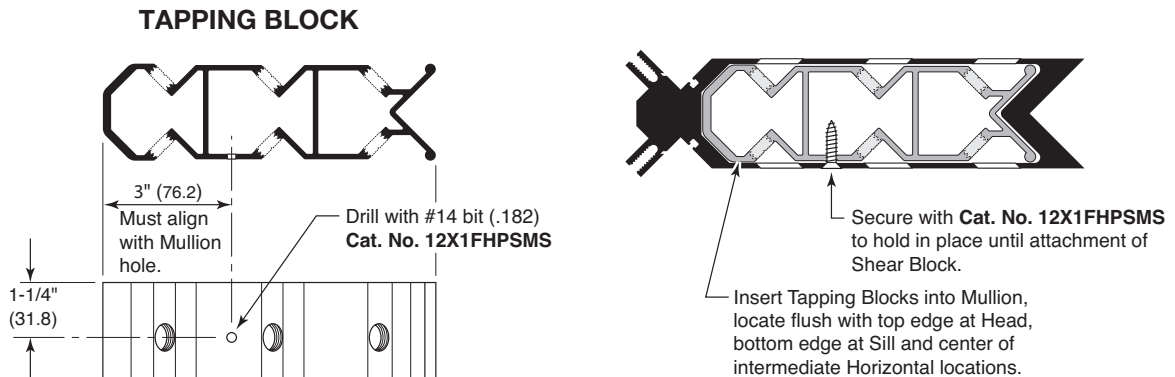

DETAIL G

NOT TO SCALE

FABRICATION

MID-SPAN ANCHOR PREPARATION

8. Slide reinforcement sleeve into mullions centering on anchor location. Drill and countersink back of mullion for #12 X 1" FH SMS (Cat. No. 12X1FHPSMS) to hold anchor reinforcement sleeve in place. See DETAIL H.
9. Drill two 17/32" diameter holes through mullion and reinforcement sleeve for anchor bolts. See DETAIL H.

NOTE: Anchor bolt and drill hole sizes can vary per individual project. Consult approved shop drawings prior to fabrication.

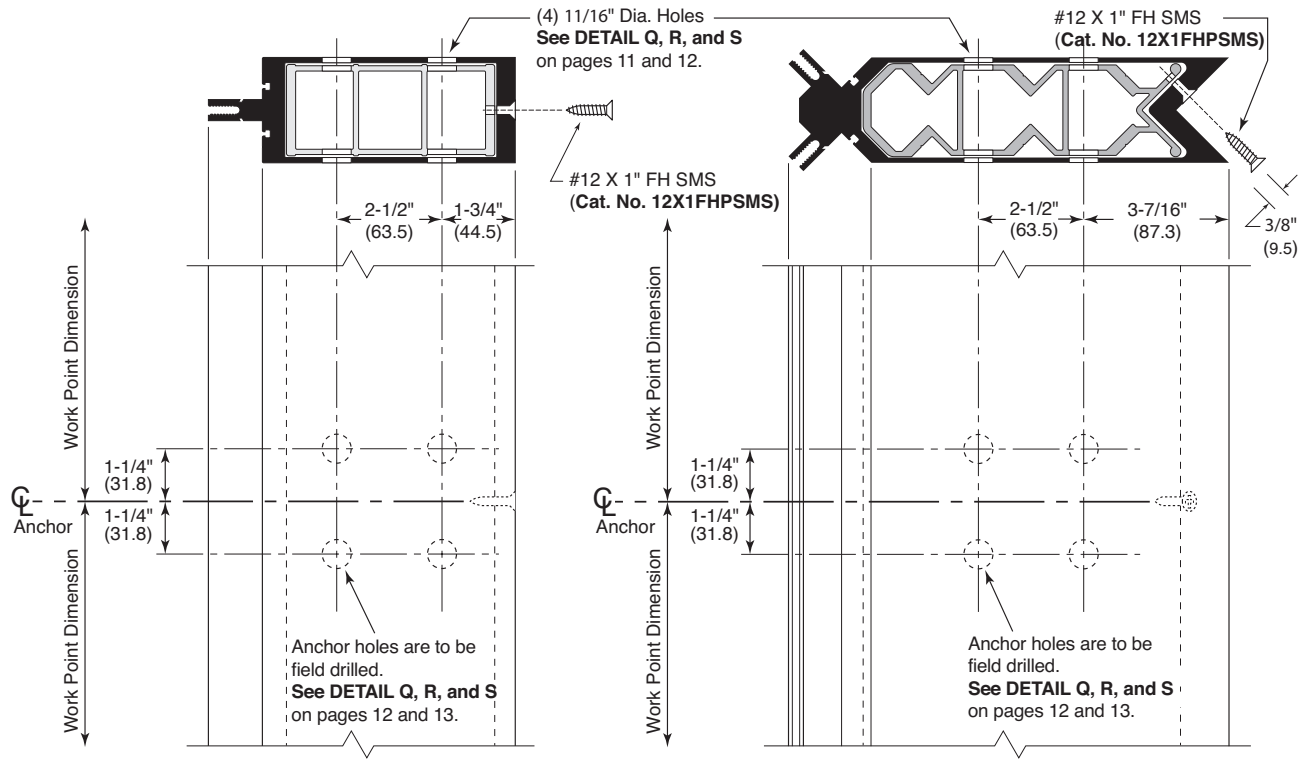

DETAIL H

10. Fabricate slots in head and sill mullion anchors as required for loading. See DETAIL I.

Jamb Anchor

Intermediate Anchor

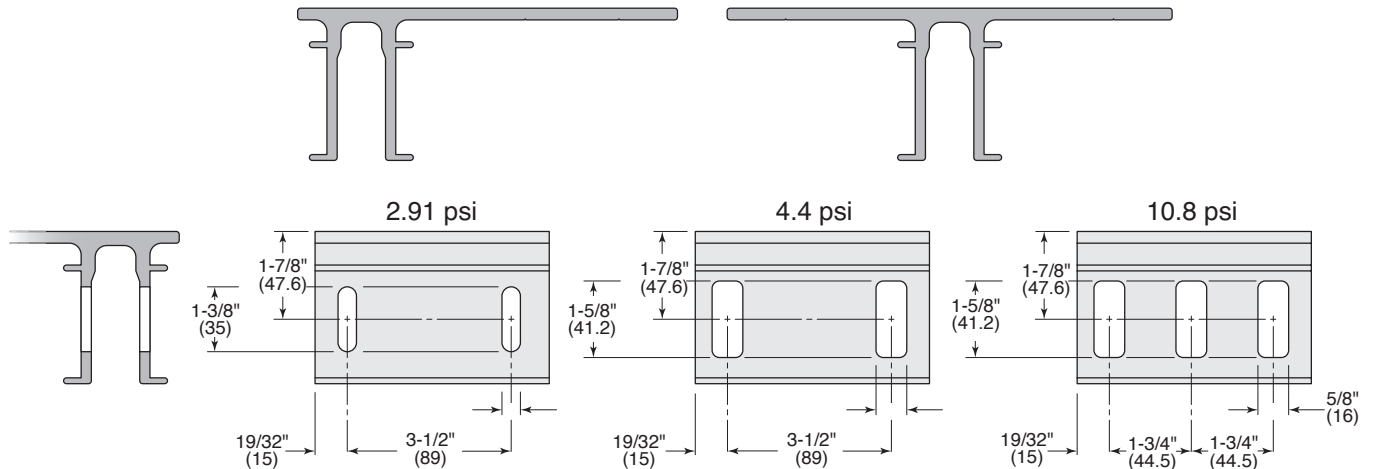

DETAIL I

NOT TO SCALE

FABRICATION

SPLICE JOINT FABRICATION

Splice joint width should be based on sealant movement capability and on the following formula:

Linear expansion for aluminum, in inches	=	Length (")	x	F° difference in temperature	x	.0000129
Linear expansion for aluminum, in millimeters	=	Length (m)	x	C° difference in temperature	x	.02322

A 1/2" (12.7) minimum joint is recommended. Use a spacer shim to set and hold the mullion joint constant during erection. Remove the shim after attaching the verticals to the anchors. Splice joints must occur in spandrel areas.

NOTE: Splice joints accommodate thermal movement only. They do not compensate for variations in floor levels.

11. Fabricate lower mullions for splice attachment screws as shown in **DETAIL J**.
12. Fabricate back of mullions for stop screw. Install stop screw. **See DETAIL J**.

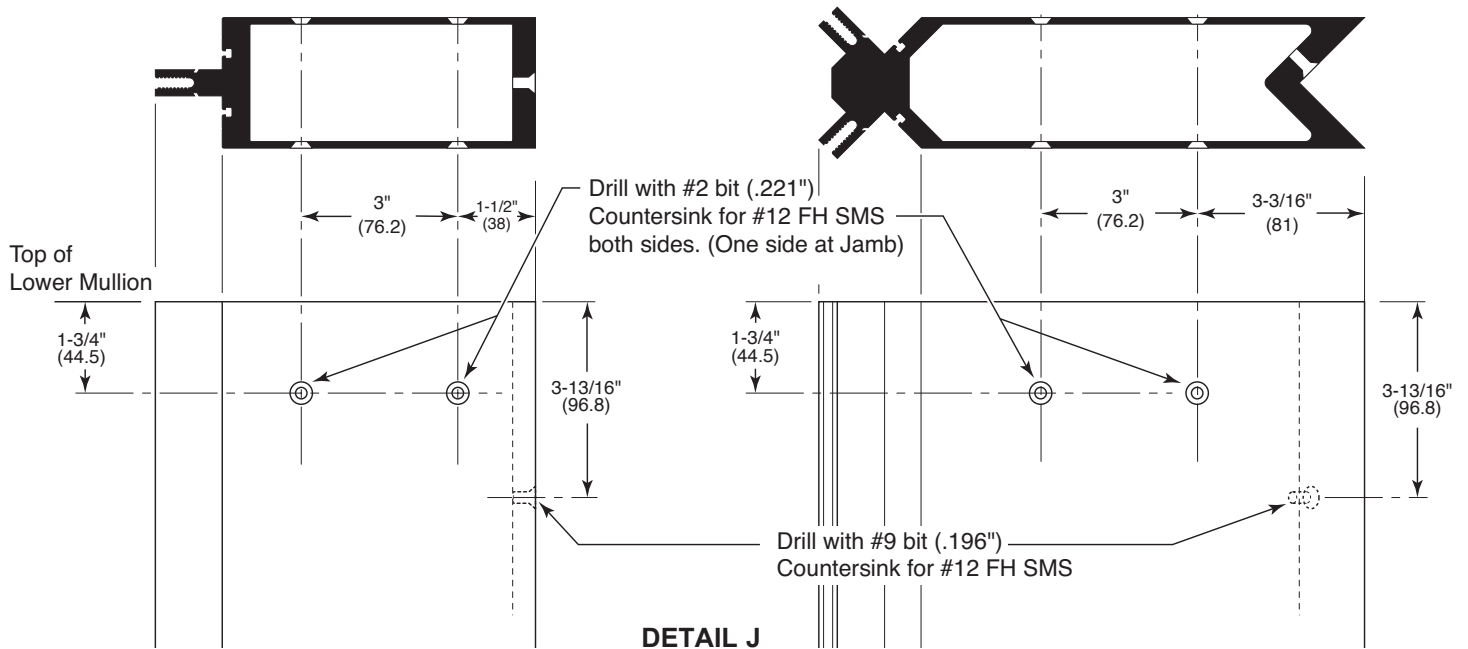

13. Clean splice sleeves and all joint surfaces. Apply bond breaker tape at areas where sleeve will be sealed to avoid three side adhesion. **See DETAIL K**.
14. Slide splice sleeve into the upper member before erection and tape to hold in place. **See DETAIL K**.

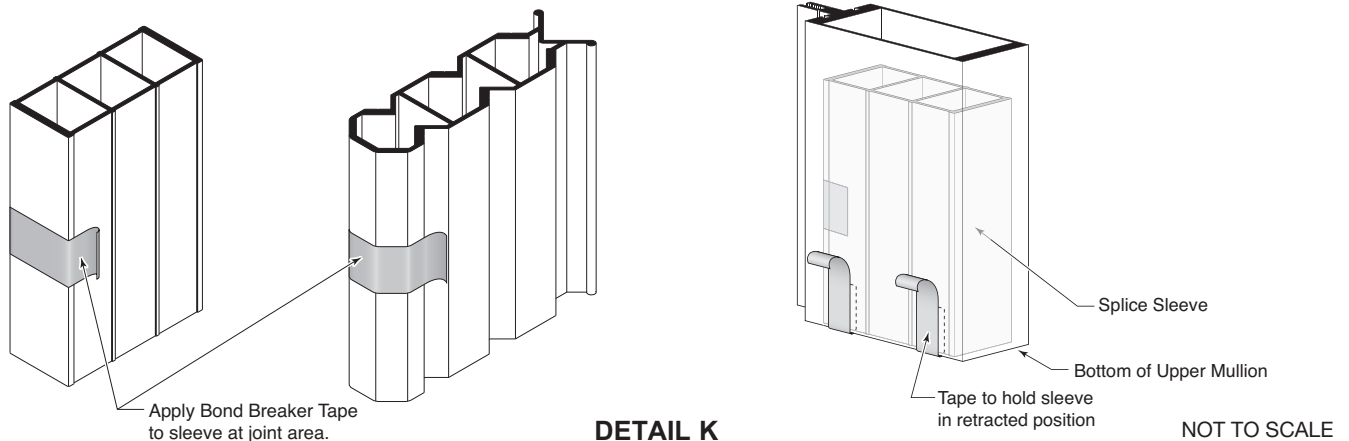

FABRICATION

PRESSURE BAR AND FACE CAP FABRICATION

15. Pressure bars are supplied with 9/32" (7.1) dia. holes at 9" (228.6) O.C. for attachment bolts. Additional holes are to be drilled 1-1/2" (38.1) from all ends and at vertical/horizontal intersections. See **DETAIL L**.
16. Fabricate two 3/16" x 1-1/2" (4.8 x 38) weep slots in horizontal pressure bars as shown on **DETAIL L**.
17. Fabricate horizontal face caps by drilling 1/4" (6.4) dia. weep holes in bottom of cap at 6" (152.4) from each end as shown on **DETAIL M**.

PRESSURE BAR FABRICATION

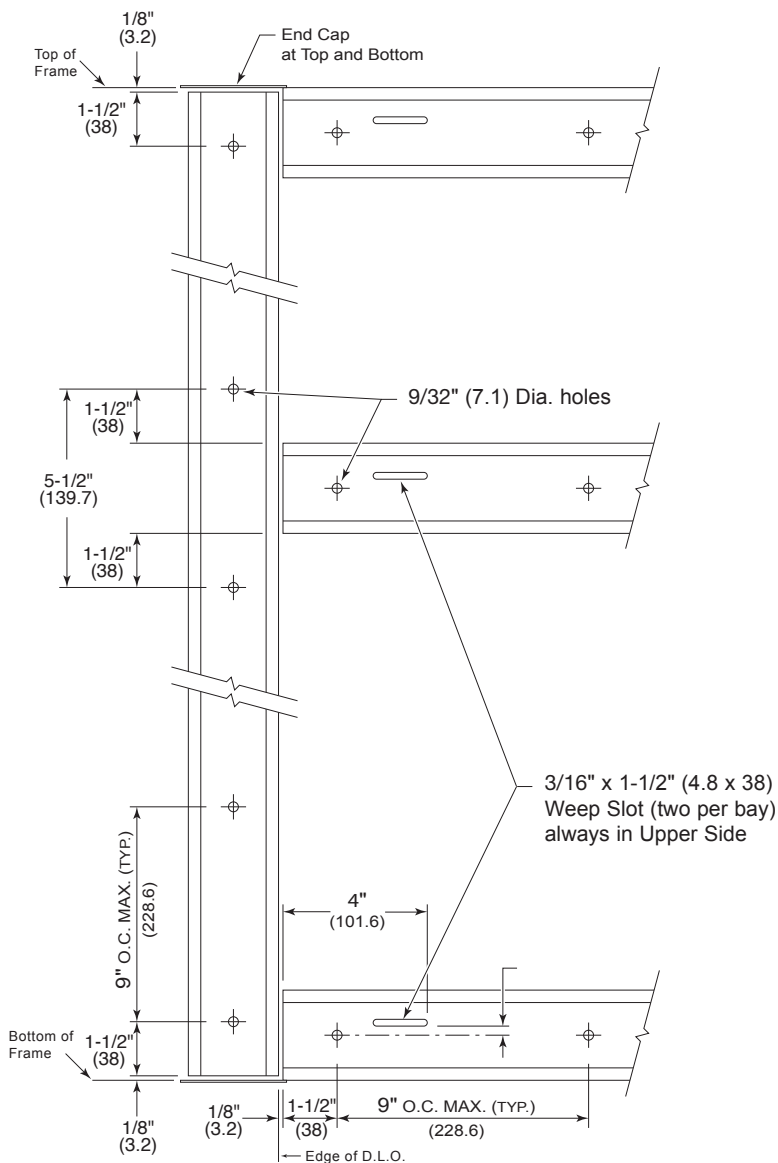

DETAIL L

FACE CAP FABRICATION

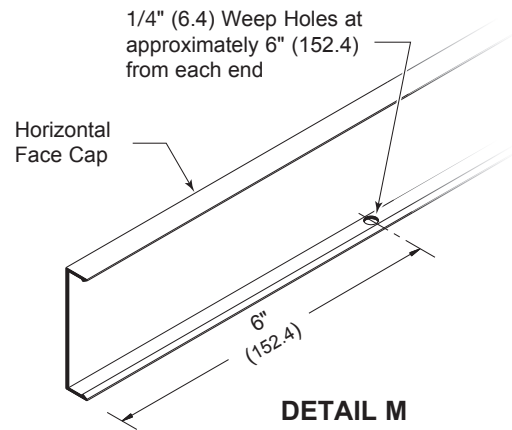

DETAIL M

NOTE: Weep Slots are required in all Horizontal Pressure Bars including the Head or Top Horizontal

NOT TO SCALE

ASSEMBLY AND INSTALLATION

SINGLE SPAN CONDITION

1. Slide top and bottom "T" anchors into vertical members. See **DETAIL N** and **O**. For corner see **DETAIL P** on page 12.
2. Install verticals plumb and level. Shim under both sides of mullion as required to adjust bottom to proper level. Shims are required under each side for proper load distribution. Secure top and bottom anchors to structure.

NOTE:
Center bolt in Shear Block is required for 10.8 psi conditions only. (Shown)

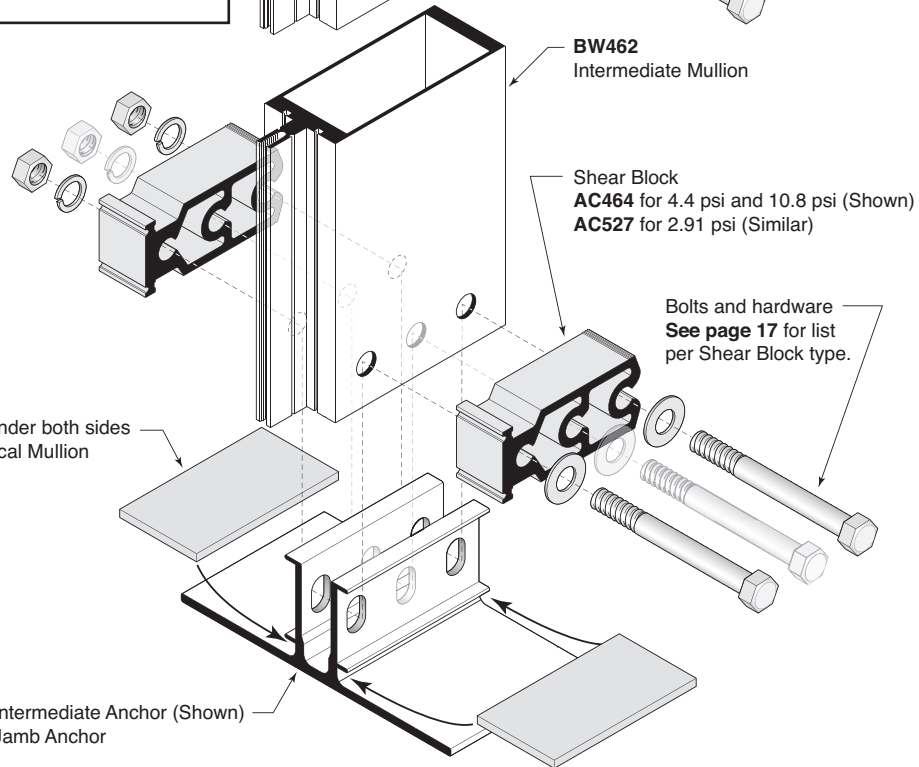
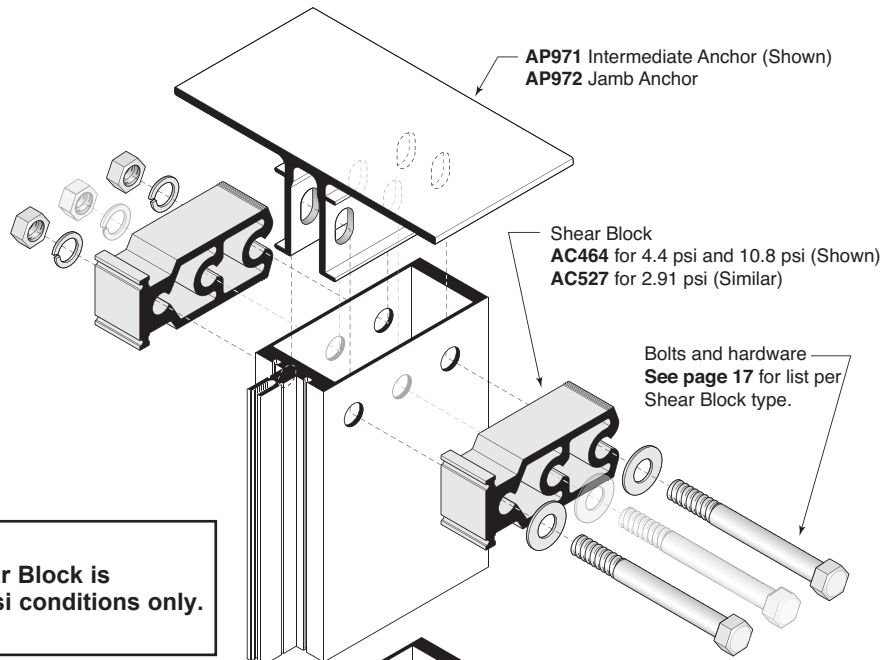

ASSEMBLY AND INSTALLATION

SINGLE SPAN CORNER CONDITION

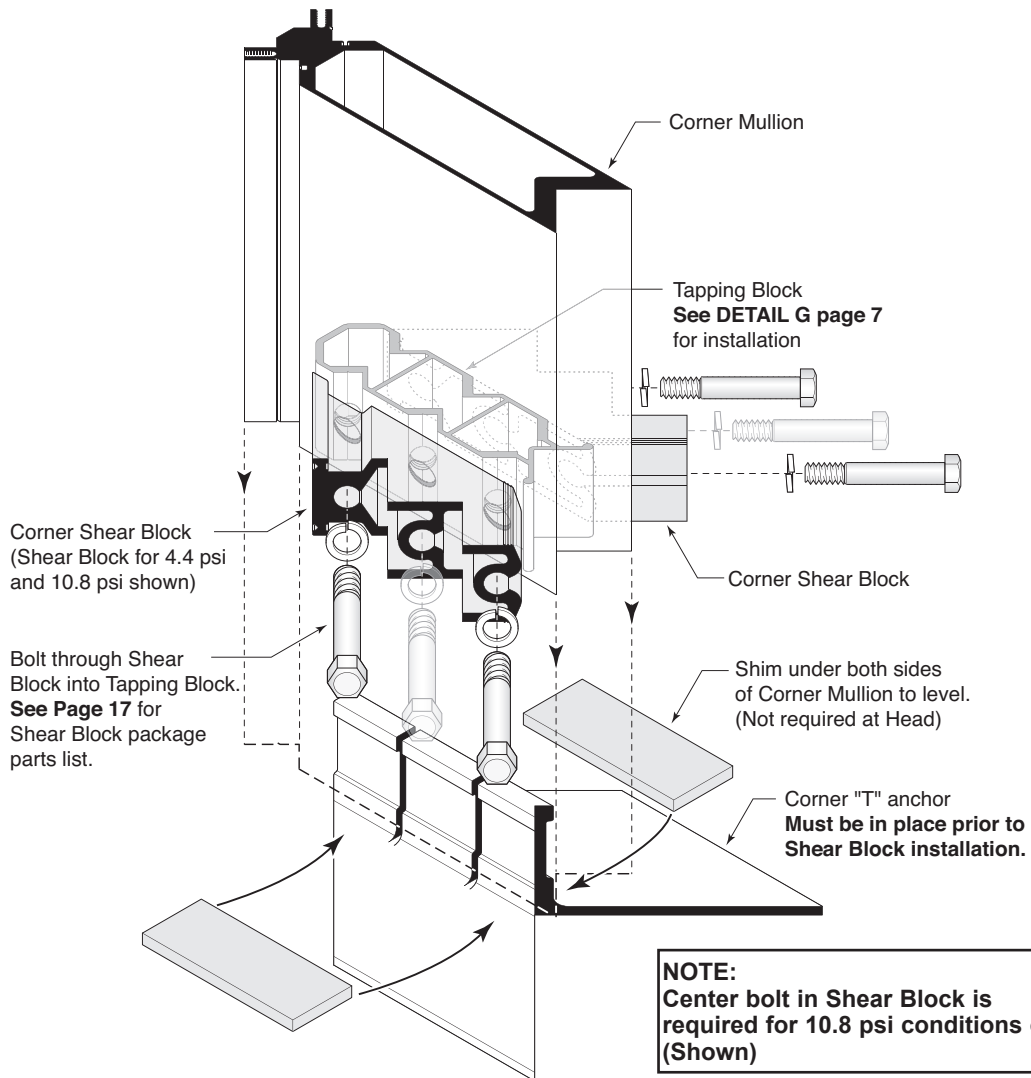

DETAIL P

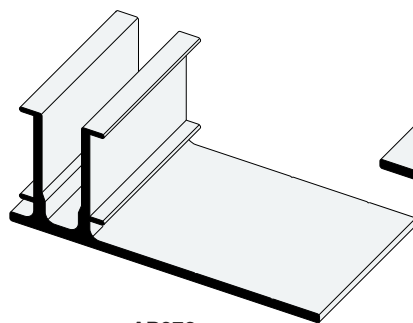

**AP972
JAMB ANCHOR**

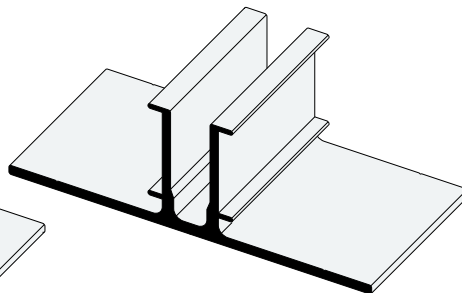

**AP971
INTERMEDIATE ANCHOR**

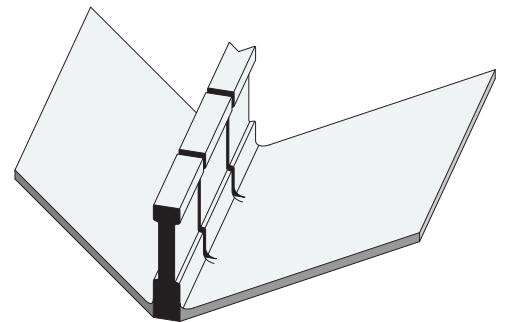

**AP492
CORNER ANCHOR**

DETAIL Q

ASSEMBLY AND INSTALLATION

MULTI-SPAN INSTALLATION

1. Install lower jambs and mullions. Slide sill anchors into bottom of mullions. Stand mullions and plumb in place.
2. Attach sill anchor to substrate. Shim under both sides of mullion as required to adjust bottom to proper level. **See DETAIL O** on page 11 and **DETAIL P** on page 12. **NOTE:** Minimum caulk space is 5/8" (16).
3. Attach floor slab anchors to floor slab edge aligned as required for vertical, plumb, and true mullion erection.
4. Install upper jamb and mullions. Stand upper mullion above previously erected mullion. Remove tape holding splice sleeve in place allowing the sleeve to telescope into the lower mullion hitting the stop screw. **See DETAIL U** on page 15.
5. Secure splice sleeve to lower mullion with (4) #12 X 1" FH SMS (Cat. No. 12X1FHPSMS) provided. **See DETAIL V** on page 15.
6. Attach mullion to floor slab anchor. Using holes in steel anchor as template, match drill (4) .531" dia. holes (17/32" drill bit) on each side through mullion and reinforcement sleeve. Attach using bolts provided. Continue this procedure until all mullions of current level are installed. **See DETAILS R, S** on page 13 and **DETAIL T** on page 14.
7. Before erecting the extreme top mullion in a column, head anchor must be inserted into top of mullion. **See DETAIL N** on page 10. Secure head anchor to structure. Repeat steps 4 and 5 for splice sleeve engagement.

NOTE: Mullion spacing must be held to within +1/32" (0.8). Check overall frame dimension every four bays to monitor dimension build up.

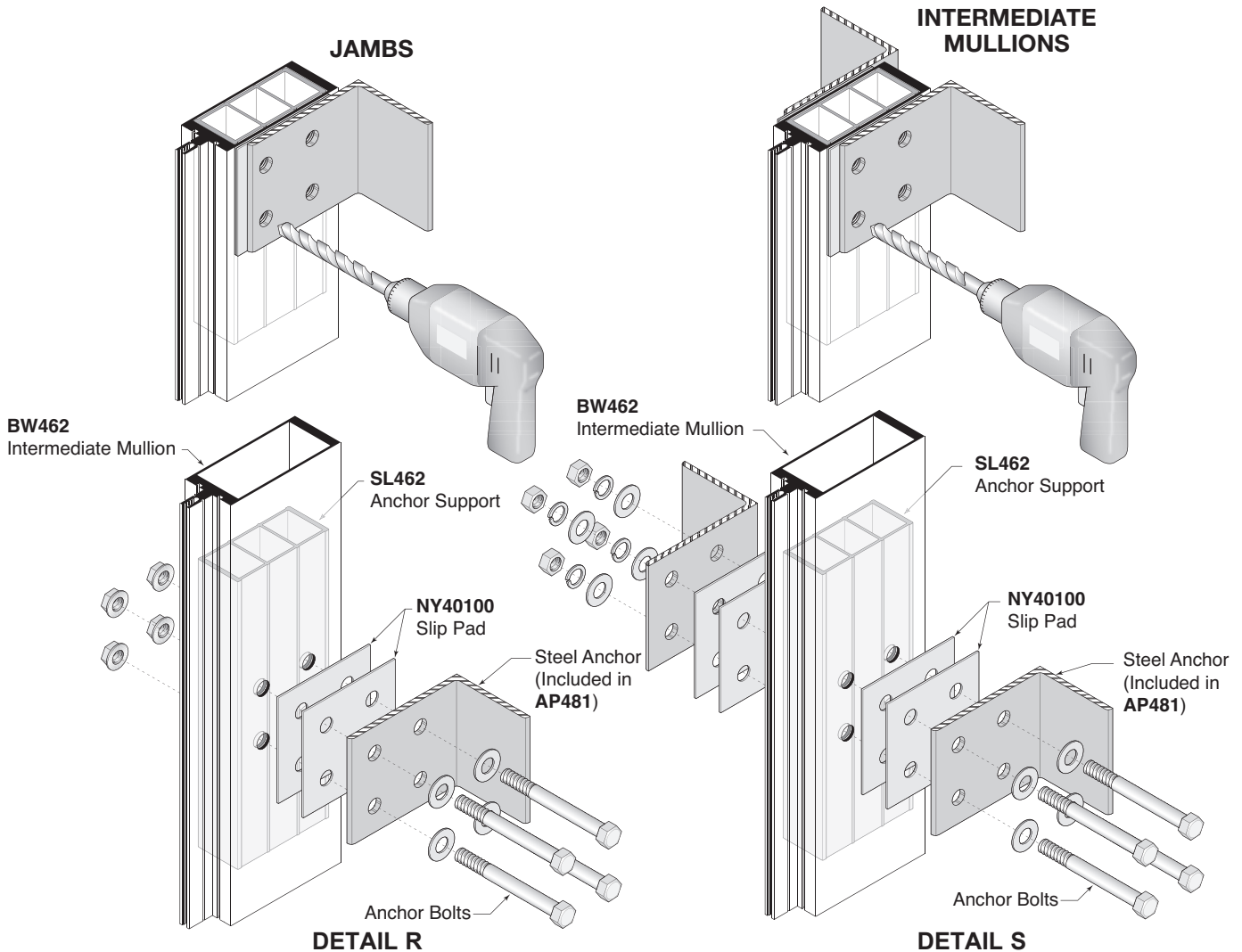

ASSEMBLY AND INSTALLATION

MULTI-SPAN CORNER INSTALLATION

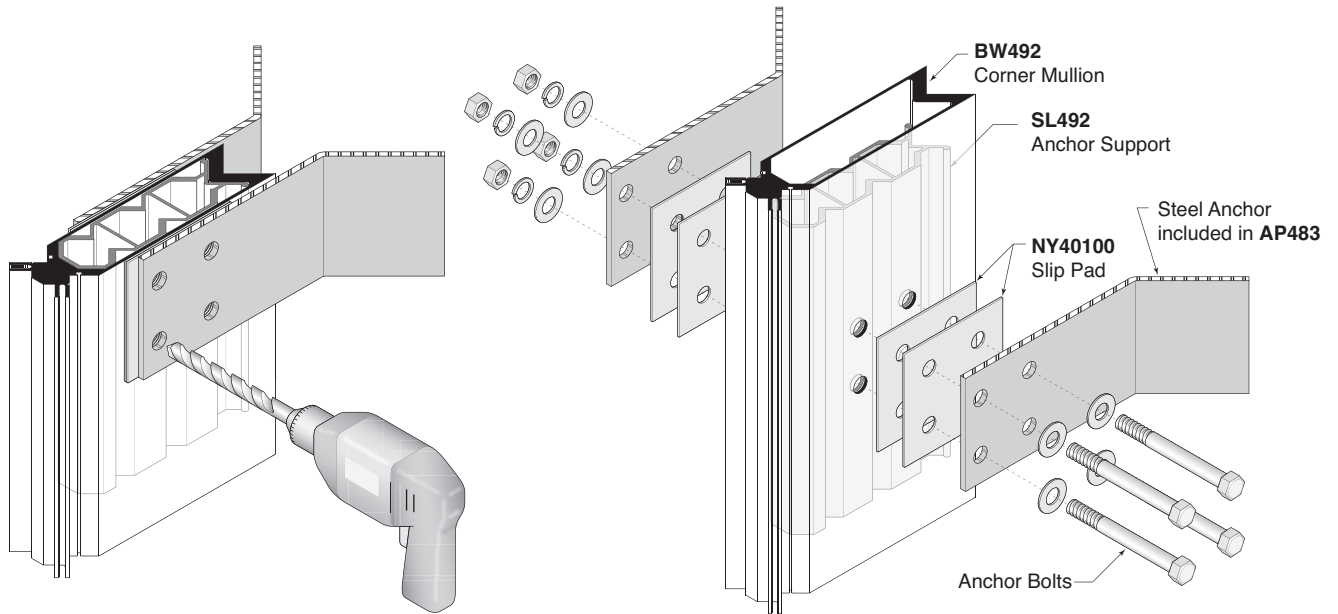

DETAIL T

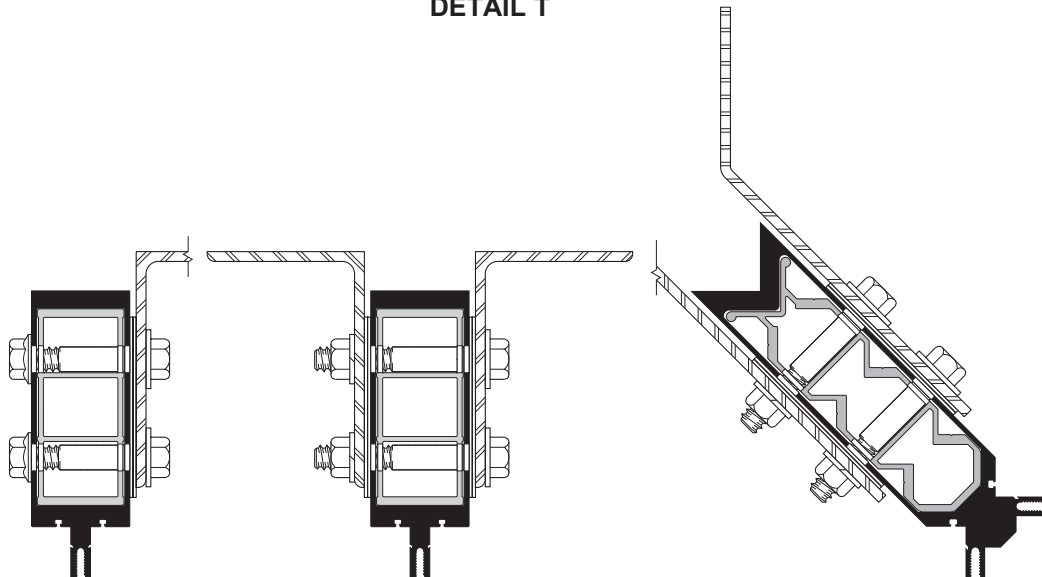

- AP481
Jamb Mullion Anchor:**
 (1) AP481 Steel Anchor
 (1) AP691 Anchor Support
 (2) NY40100 Slip Pads
 (4) 5/8"-11 x 3-1/2" GR5 Bolts
 (4) 5/8" Lock Washers

- AP482
Intermediate Mullion Anchor:**
 (2) AP482 Steel Anchors
 (1) AP691 Anchor Support
 (4) NY40100 Slip Pads
 (4) 5/8"-11 x 4-1/2" GR5 Bolts
 (4) 5/8" Flat Washers
 (4) 5/8" Lock Washers
 (4) 5/8"-11 Hex Nuts, NyLoc

- AP483
Corner Mullion Anchor:**
 (2) AP483 Steel Anchors
 (1) AP492 Anchor Support
 (4) NY40100 Slip Pads
 (4) 5/8"-11 x 4-1/2" GR5 Bolts
 (4) 5/8" Flat Washers
 (4) 5/8" Lock Washers
 (4) 5/8"-11 Hex Nuts, NyLoc

DETAIL U

ASSEMBLY AND INSTALLATION

SPLICING MULLION PRESSURE BAR AND FACE COVER

1. Install upper member and let splice sleeve slide down until it sits on top of stop screw. Match drill through lower mullion attachment holes into splice sleeve with #15 drill bit (.180"). Secure splice sleeve to lower mullion with (4) #12 X 1" FH SMS (Cat. No. 12X1FHPSMS) provided. See **DETAIL V**. Also see **Multi-Span Installation** on page 13.

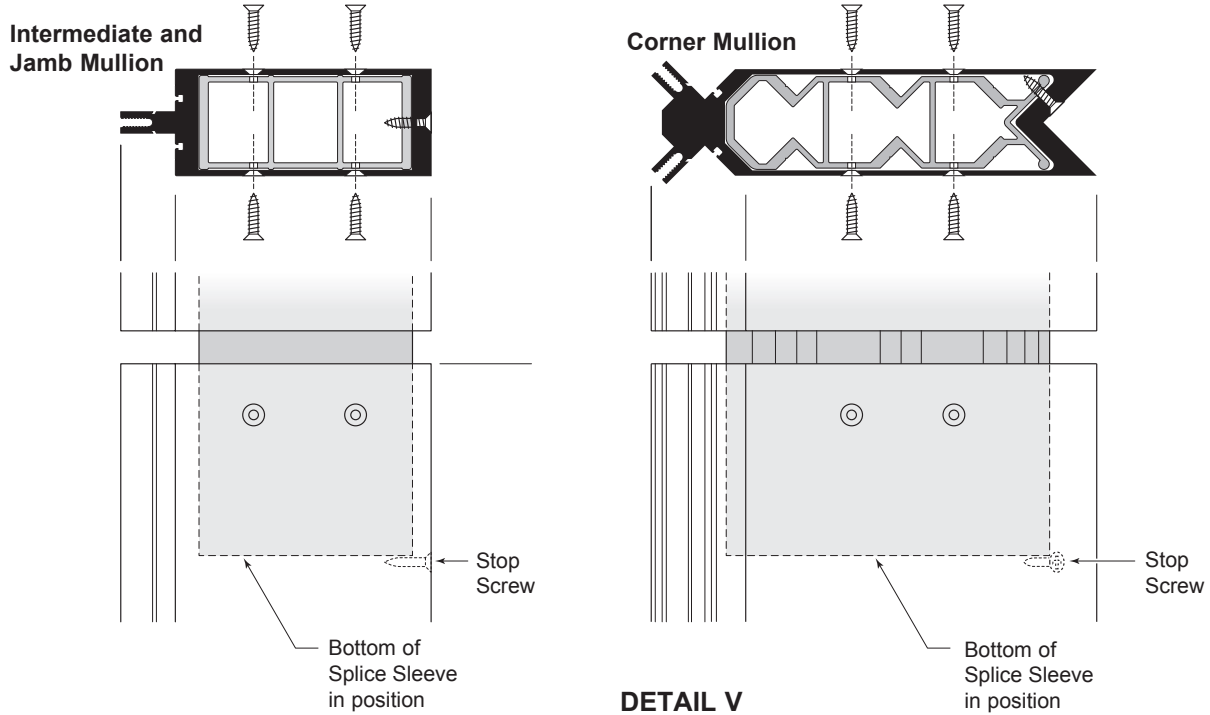

DETAIL V

2. Stagger joints on back members, pressure bars and face caps. Seal joints as shown on **DETAIL W**.
3. Seal pressure bar joint. See **DETAIL W**.

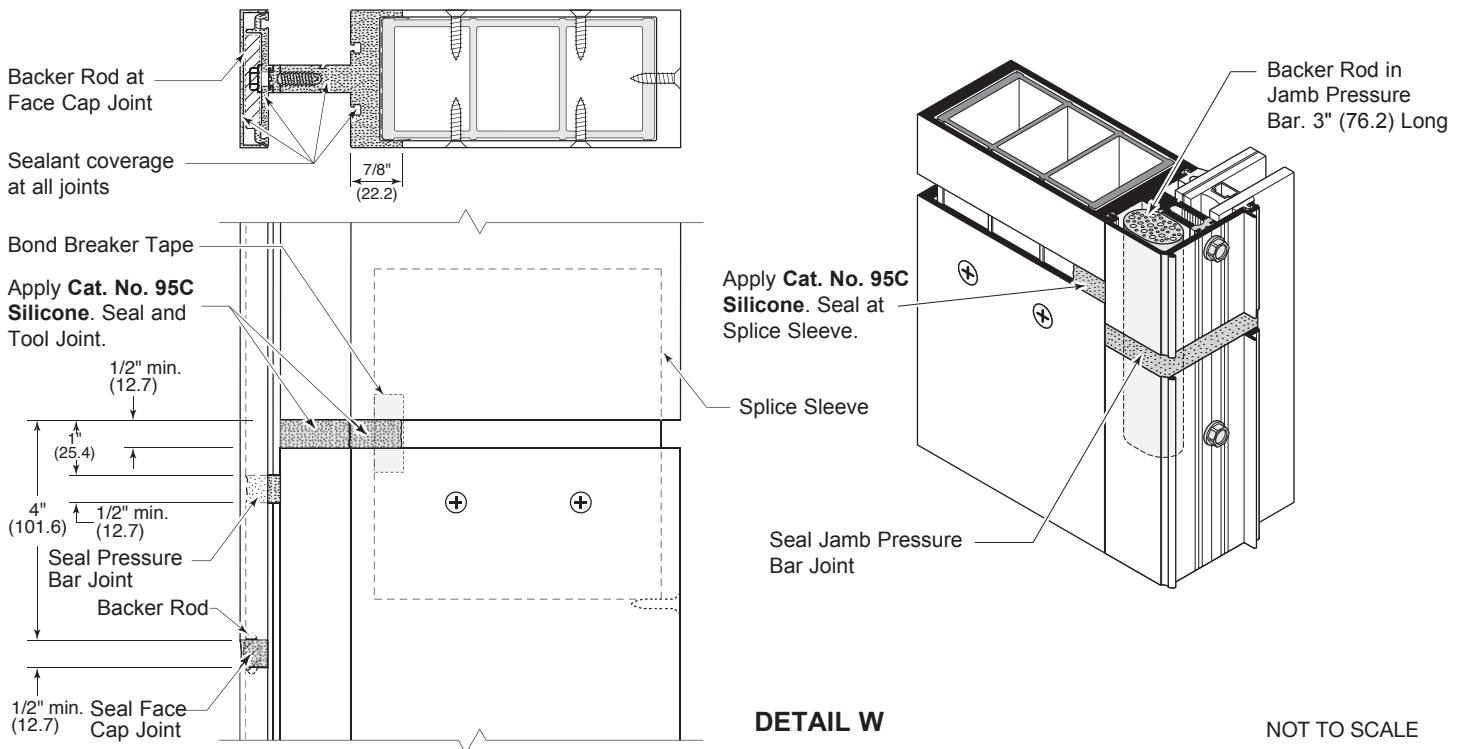

NOT TO SCALE

ASSEMBLY AND INSTALLATION

SHEAR BLOCK AND HORIZONTAL INSTALLATION

1. Attach shear blocks to vertical members. Install head, intermediate horizontal and sill shear blocks as shown in DETAILS X through Z.

NOTE: Intermediate shear blocks can be installed prior to mullion erection. Head and sill shear blocks must be installed after erection.

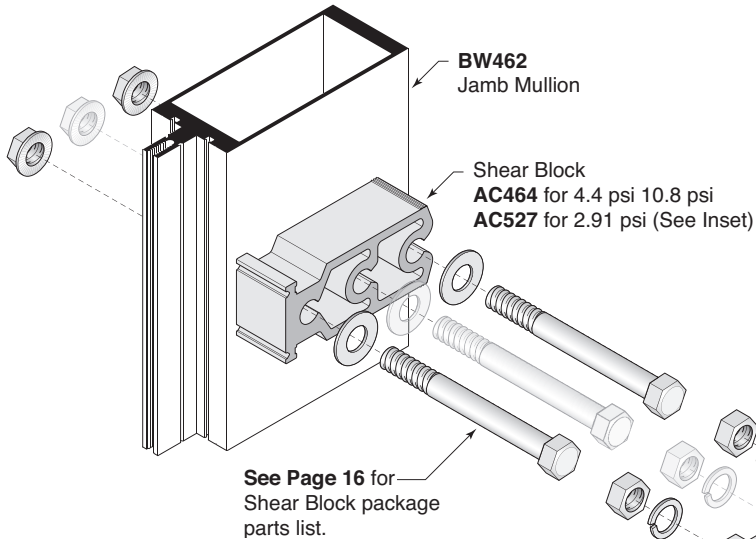

DETAIL X

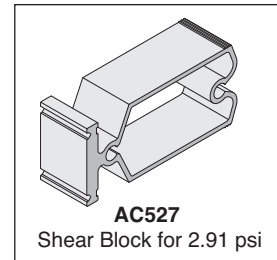

NOTE:
Center bolt in Shear block is required for 10.8 psi conditions only. (Shown)
See Detail AA on page 17

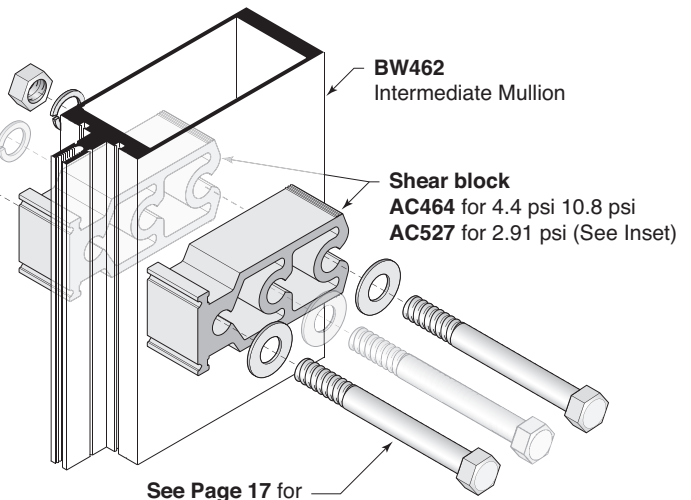

DETAIL Y

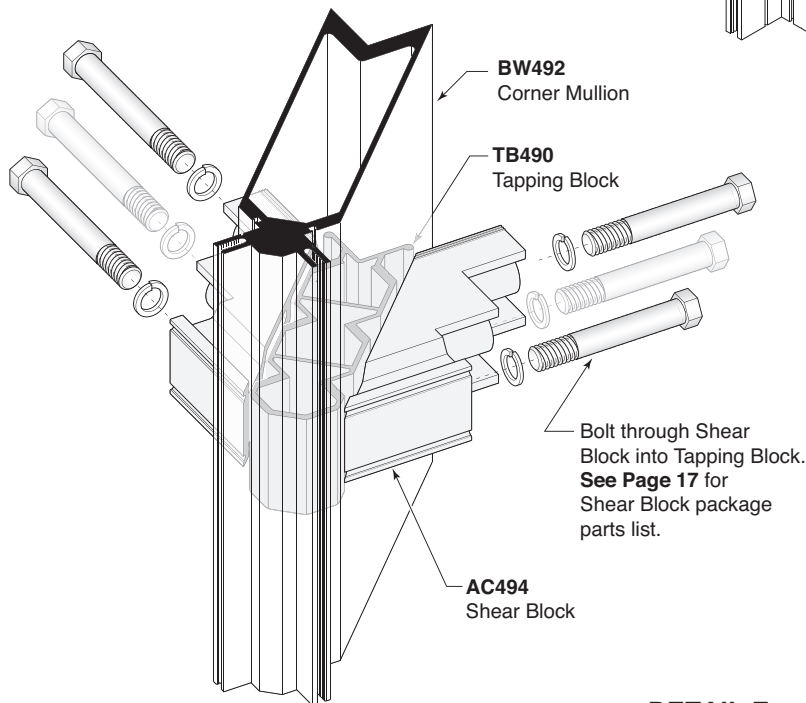

DETAIL Z

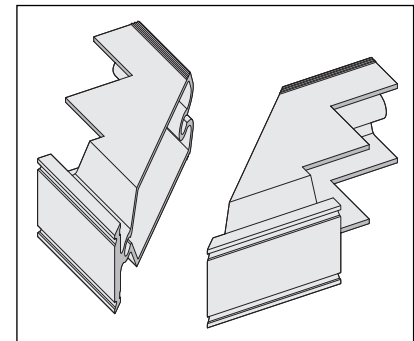

ASSEMBLY AND INSTALLATION

SHEAR BLOCK AND HORIZONTAL INSTALLATION (Continued)

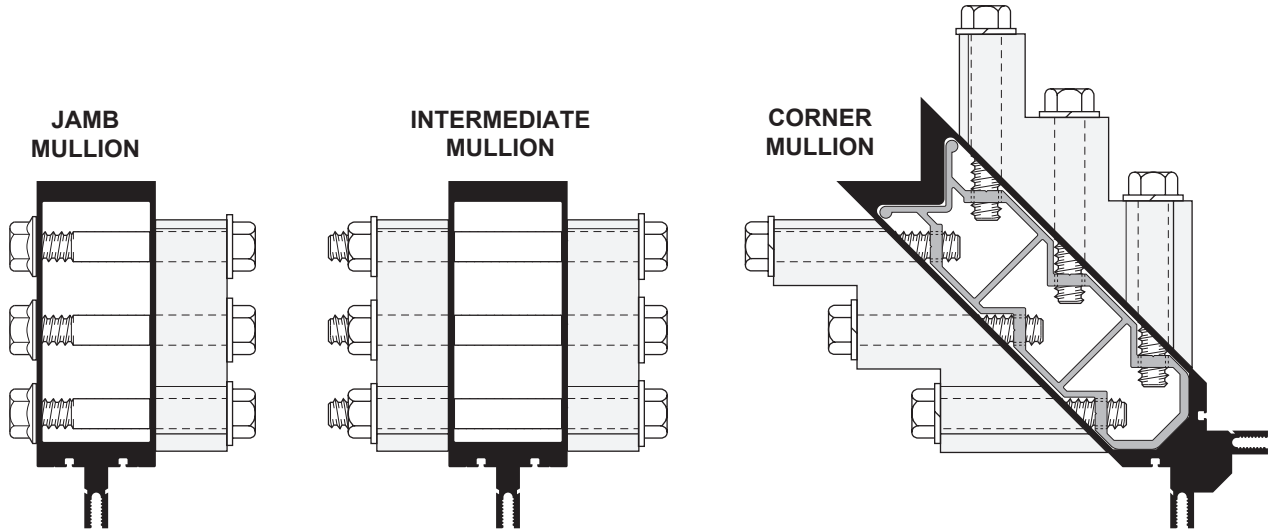

AP53899 for 2.91 psi:

- (1) AC527 Shear block
- (2) MF353 3/8"-16 x 5" GR5 bolts
- (2) MF251 3/8" Flat Washers
- (2) MF304 3/8"-16 Flange Nut
- (2) Cat. No. 12X1FHPSMS

APK464 for 4.4 psi:

- (1) AC464 Shear Block
- (2) MF545 5/8"-11 x 4-1/2" GR5 Bolts
- (2) MF255 5/8" Flat Washers
- (2) MF529 5/8"-11 Flange Nut
- (2) Cat. No. 12X1FHPSMS

AP46799 for 10.8 psi (Shown):

- (1) AC464 Shear Block
- (3) MF545 5/8"-11 x 4-1/2" GR5 Bolts
- (3) MF255 5/8" Flat Washers
- (3) MF529 5/8"-11 Flange Nut
- (2) Cat. No. 12X1FHPSMS

AP52799 for 2.91 psi:

- (2) AC527 Shear Blocks
- (2) MF368 3/8"-16 x 6-1/2" GR5 Bolts
- (2) MF251 3/8" Flat Washers
- (2) MF265 3/8"-16 Hex Nuts, NyLoc
- (4) Cat. No. 12X1FHPSMS

AP46599 for 4.4 psi:

- (2) AC464 Shear Blocks
- (2) MF565 5/8"-11 x 6-1/2" GR5 Bolts
- (2) MF255 5/8" Flat Washers
- (2) MF219 5/8"-11 Hex Nuts, NyLoc
- (4) Cat. No. 12X1FHPSMS

AP46899 for 10.8 psi (Shown):

- (2) AC464 Shear Blocks
- (3) MF565 5/8"-11 x 6-1/2" GR5 Bolts
- (3) MF255 5/8" Flat Washers
- (3) MF219 5/8"-11 Hex Nuts, NyLoc
- (4) Cat. No. 12X1FHPSMS

AP53999 for 2.91 psi:

- (2) AC539 Shear Block
- (4) MF342 3/8"-16 x 4" GR5 Bolts
- (4) MF254 3/8" Lock Washers
- (1) TB539 Tapping Block
- (5) Cat. No. 12X1FHPSMS

APK494 for 4.4 psi:

- (2) AC494 Shear Block
- (4) MF540 5/8"-11 x 4" GR5 Bolts
- (4) MF256 5/8" Lock Washers
- (1) TB490 Tapping Block
- (5) Cat. No. 12X1FHPSMS

AP49799 for 10.8 psi (Shown):

- (2) AC494 Shear Block
- (6) MF540 5/8"-11 x 4" GR5 Bolts
- (6) MF256 5/8" Lock Washers
- (1) TB490 Tapping Block
- (5) Cat. No. 12X1FHPSMS

DETAIL AA

NOTE:
Center bolt in Shear Block is required for 10.8 psi conditions only. (Shown)

ASSEMBLY AND INSTALLATION

SHEAR BLOCK AND HORIZONTAL INSTALLATION (Continued)

2. Apply **CRL RTV408 silicone sealant** to shear block face prior to installing horizontal members as **shown on DETAIL BB**.
3. Roll horizontal members over shear blocks and secure with screws provided. **See DETAIL CC**.
4. Install snap-in horizontal fillers. **See DETAIL CC**.

NOTE: Snap-in fillers are optional at head and sill to facilitate interior caulking. Cut fillers 3-3/4" short to clear shear blocks. Snap fillers in place before installing head and sill members.

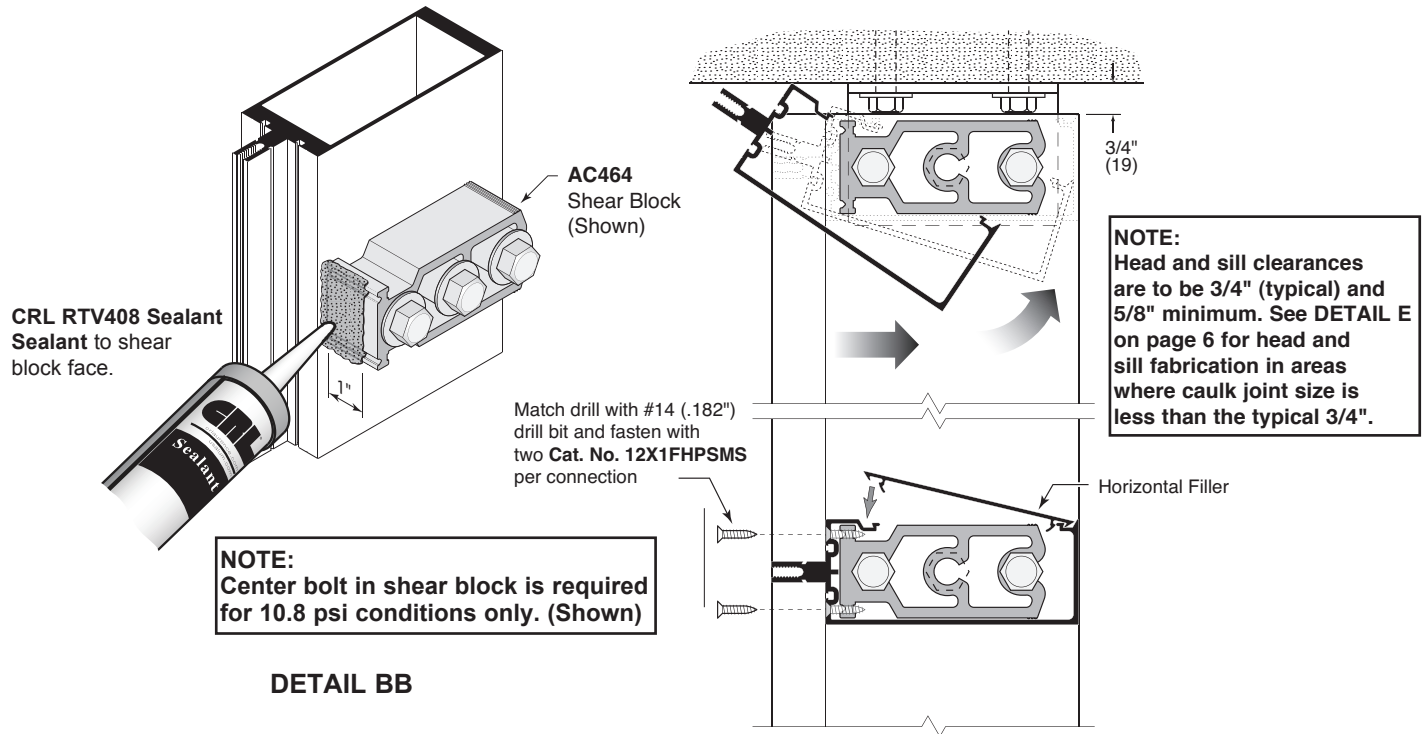

PERIMETER SEAL PROCEDURE

1. Install closure plates at top and bottom of vertical mullions. **See DETAIL DD**.
2. Closure plates that occur at entrance locations must be trimmed flush with mullion edge at door side for door frame clearance. **See DETAIL DD**.

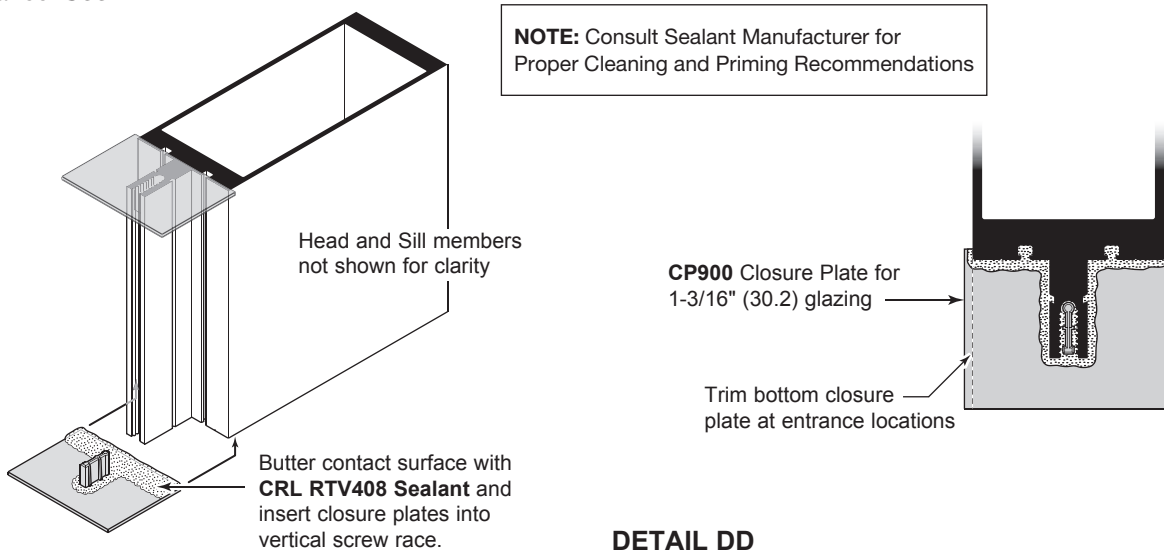

ASSEMBLY AND INSTALLATION

PERIMETER SEAL PROCEDURE (Continued)

3. After back members are installed, seal around perimeter with **Cat. No. 95C/M64/M66**. Perimeter caulking must be completed prior to installation of glass and pressure bars. Ensure perimeter sealant has smooth transition across vertical closure plates. **See DETAIL EE.**

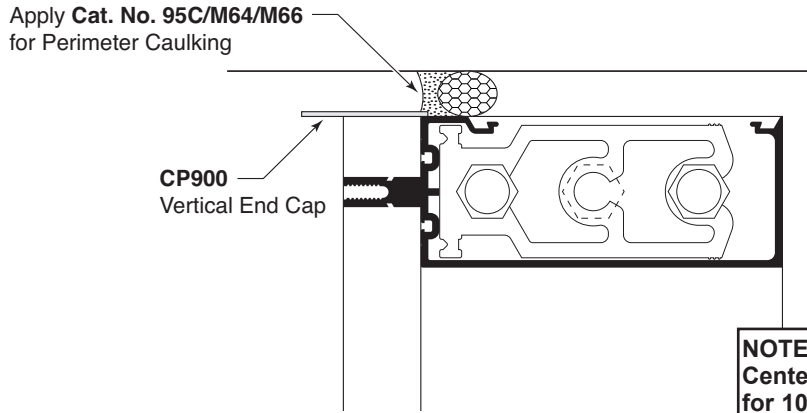

DETAIL EE

NOTE:
Center bolt in Shear Block is required for 10.4 psi conditions only. (Dashed)
See Detail AA on page 16

GLAZING

GLASS OPENING PREPARATION

1. Seal joint between horizontal and vertical. Seal over screw heads in the glazing pockets.
2. Apply **CRL RTV408 silicone sealant** at the three contact areas of End Dams and the vertical gasket reglet at the End Dam location. **See DETAIL FF.**
3. Slide End Dams into place. **See DETAIL FF.**
NOTE: End Dams occur at head and sill also.

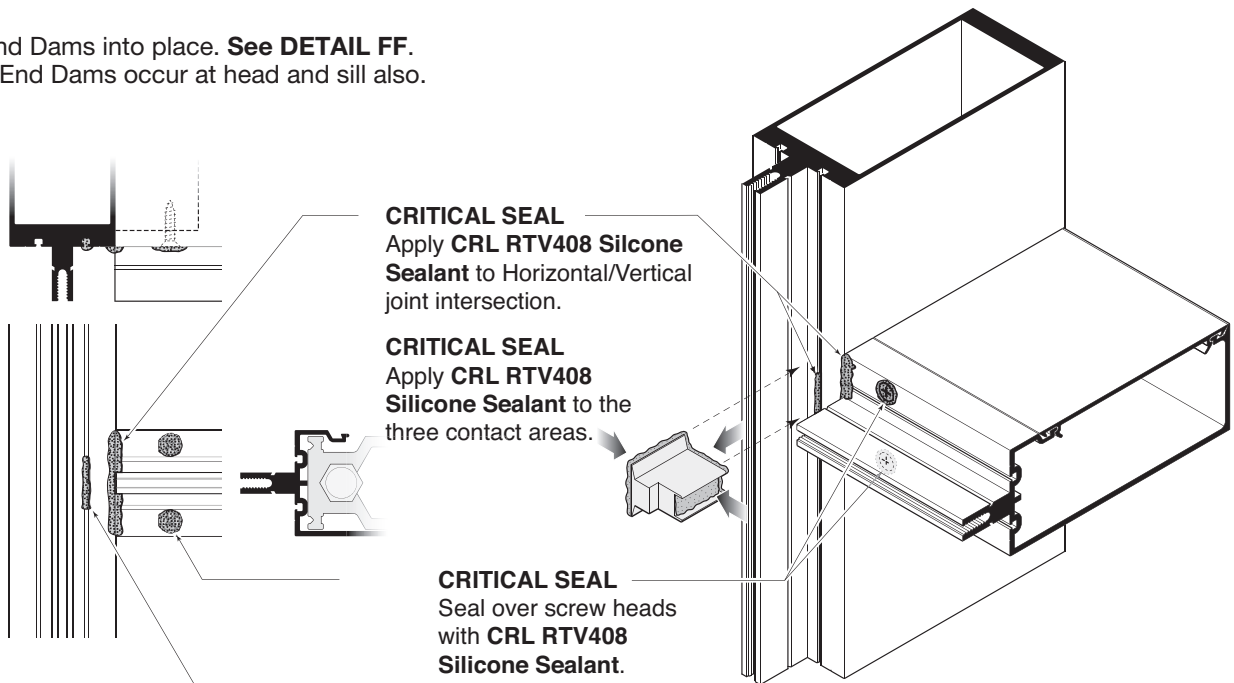

DETAIL FF

NOTE: Consult Sealant Manufacturer for Proper Cleaning and Priming Recommendations

GLAZING

GLASS OPENING PREPARATION (Continued)

4. Cut spacer gaskets to length. Vertical length is to be D.L.O. plus 1-5/8" (41.3). Horizontal length is to be D.L.O. plus 1-1/8" (28.2).
5. Cut dart from both ends of the horizontal spacer gaskets as shown in **DETAIL GG**.
6. Install interior spacer gaskets into vertical and horizontal members.
7. Install exterior gaskets into pressure bars. Horizontal pressure bar gaskets should extend 1/8" (3.2) beyond each end of the extrusions. Vertical pressure bar gaskets run continuous.
8. Apply **CRL RTV408 Silicone Sealant** to face of End Dams. This is a critical seal area. **See DETAIL HH.** This should be done immediately before installation of vertical pressure bar.

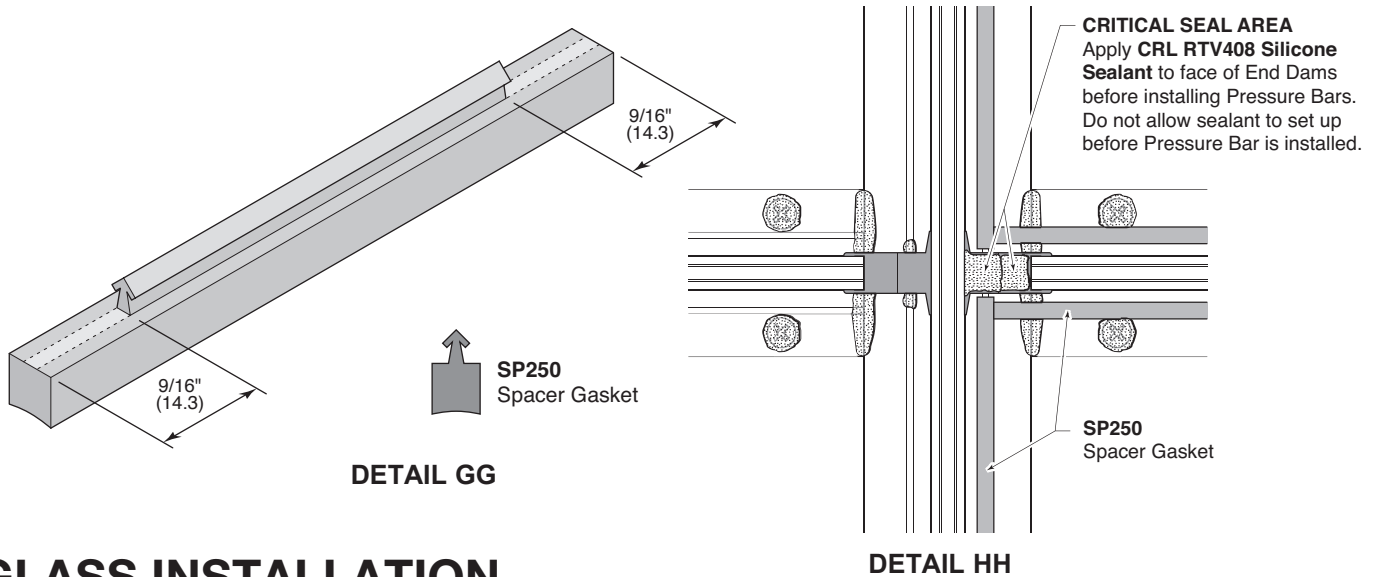

GLASS INSTALLATION

GLASS SIZES: GLASS WIDTH AND HEIGHT = DAY LIGHT OPENING + 1-3/8" (34.9)

NOTE: Formula does not take into account glass tolerances. Consult glass manufacturer before ordering glass.

Remove exterior gaskets from carton and lay flat in a clean, dry area in order to recover shape. Allow gaskets to relax at least two hours at temperatures above 50°F (10°C). Glaze with gaskets above 40°F (4.44°C).

If necessary warm gaskets in a hot box before installing. Use **NP430** gasket at exterior. Cut gaskets allowing 1/8" (3.2) extra length per foot of extrusion to allow for shrinkage.

1. Install setting blocks. Position two setting blocks for each lite of glass at quarter points or per approved shop drawings. **See DETAIL II.**

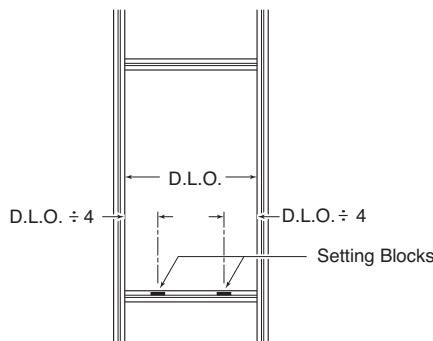

NOT TO SCALE

GLAZING

GLASS INSTALLATION (Continued)

2. Install glass and center in opening. Use **CW368** temporary glass retainers to hold glass in place until pressure bars are installed. Install temporary glass retainer at corners and one at mid-light. See **DETAIL JJ**.

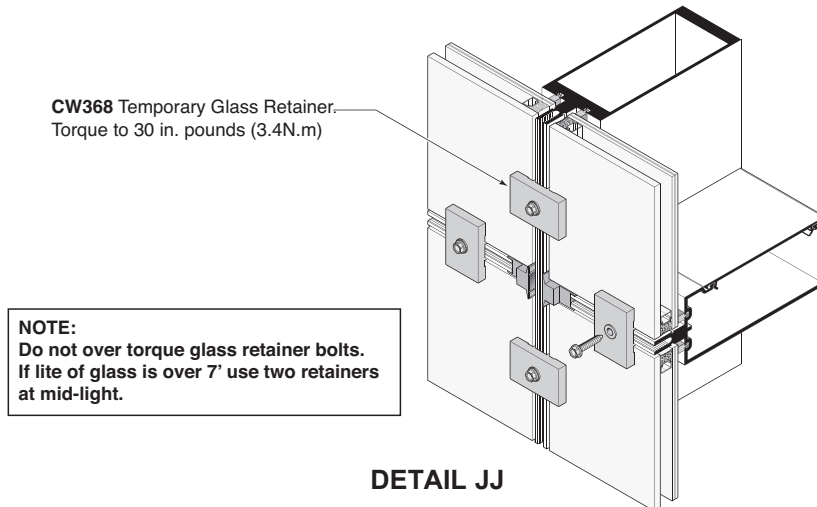

PRESSURE BAR INSTALLATION

Install vertical pressure bar bolts from bottom to top and horizontal pressure bar bolts from center outward. Always locate bolts 1-1/2" (38.1) maximum from vertical/horizontal intersections to ensure proper pressure over end dams. See **DETAIL BB**. Be sure pressure bar spacer is not disengaged.

NOTE: See **DETAIL V** on page 15 for pressure bar splice condition.

1. Install gaskets into vertical and horizontal pressure bars.
2. Install vertical pressure bars first. Leave 1/8" (3.2) gaps at top and bottom. Using a speed wrench, torque bolts to 30 inch pounds (3.4 N.m). Increase torque to 50-60 inch pounds, (5.7 to 6.8 N.m) minimum after all four sides have been secured.
3. Center horizontal pressure bars in opening, leaving 1/8" (3.2) gaps at each end.
NOTE: weep slots **must be** in top side of all horizontal pressure bars and level with bottom of glazing pocket to ensure proper drainage. See **DETAIL KK**.
4. Seal gaps at vertical/horizontal intersections, screw heads, and at top and bottom of vertical pressure bars. See **DETAIL KK**.

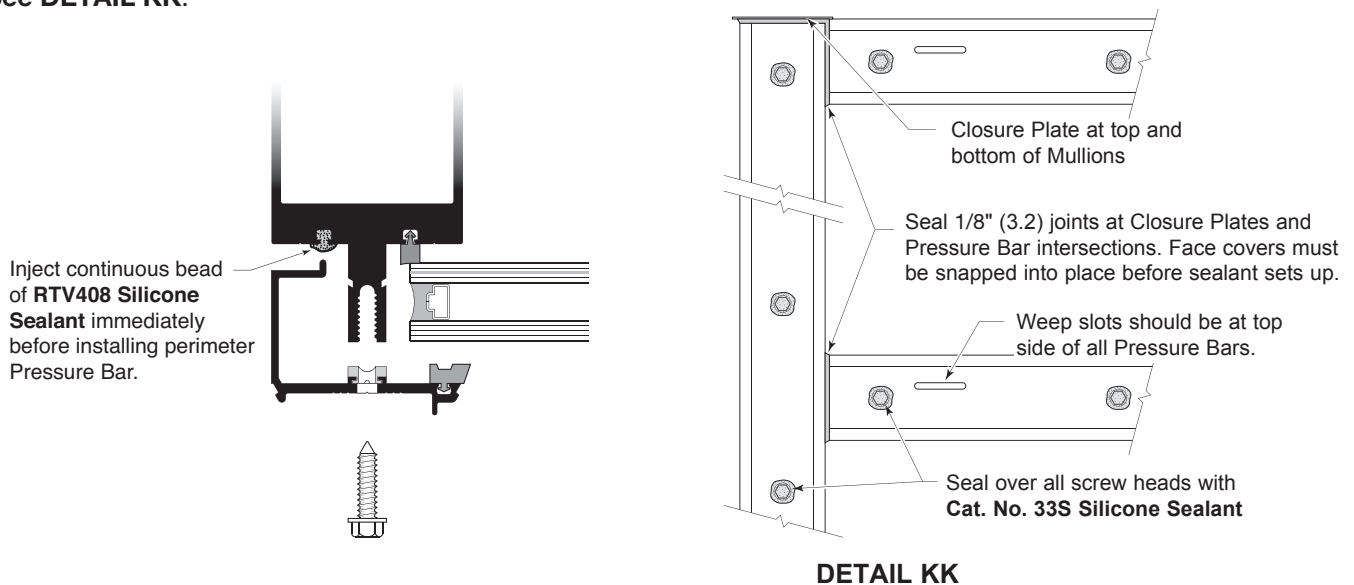

GLAZING STRUCTURAL SILICONE

Aluminum framing surfaces and glass edge areas to receive structural silicone must be clean.

- Inject structural silicone into space between glass and back members on all four sides of opening and tool.
See **DETAIL LL**. Follow manufacturer's recommendations for cure times.
NOTE: Always follow structural silicone manufacturer's instructions and recommendations for surface preparation and silicone application.

NOTE: Silicone must be free of air pockets or bubbles and penetrate full depth of space continuously.

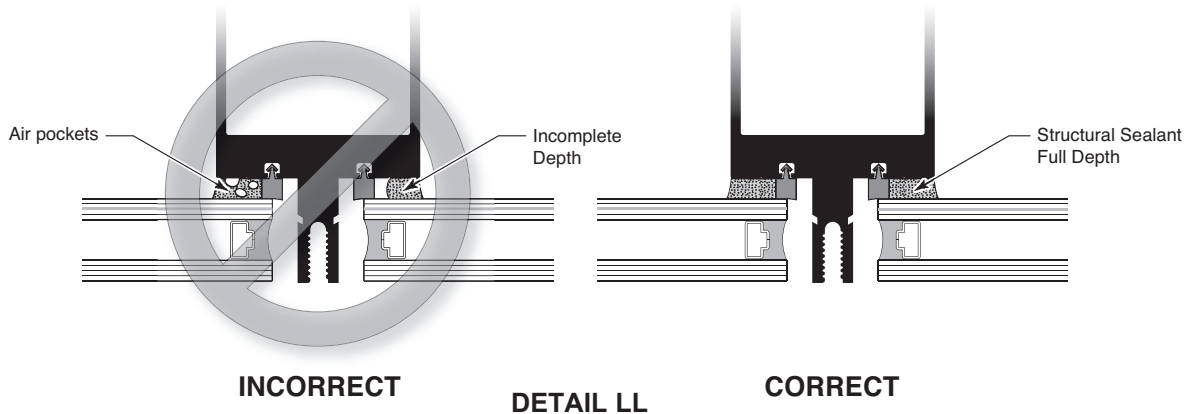

FACE COVER INSTALLATION

Care must be taken to prevent damage of face covers during installation. Use a piece of wood such as 2" x 4" x 12" (50 x 100 x 300) and a **Cat. No. 2M CRL 2 Lb. Rubber Mallet**.
See **DETAIL MM**.

- Install vertical face covers first. Do not disturb top and bottom closure plates when installing face covers. Pinning of vertical face cover is required to prevent slippage. Use one pin on each side per cut length concealed behind horizontal face cover. See **DETAIL NN**.
- Install horizontal face covers with the weep holes located on the bottom side.

NOTE: See DETAIL P on page 12 for face cover splice condition.

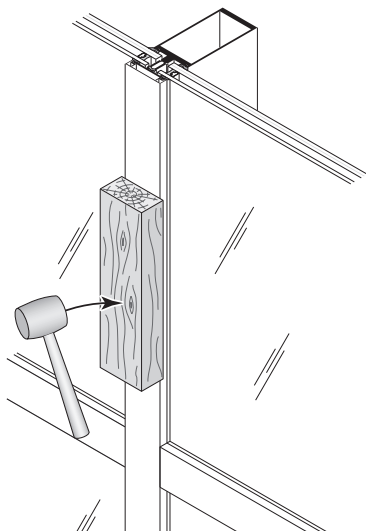

DETAIL MM

1/16" x 1/2" (1.6 x 12.7) roll pin at center of cut length on each side. (Concealed behind Horizontal Face Cover)

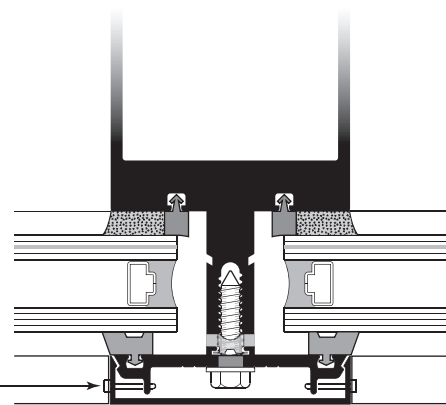

DETAIL NN



GUIDE TO SEALANTS

WATERPROOFING

- CRL 33S ACETIC CURE SILICONE

NOTE: Not for use near insulating glass units with butyl sealant.

Fill with Sealant to Create a Water Shed.
CAT. NO. 33S Silicone

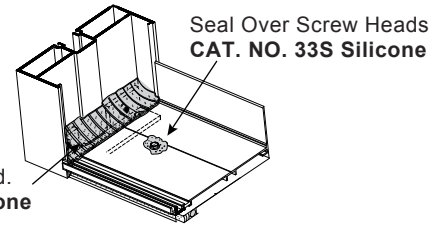

Sill to Subsill, End Dams, Screw Heads, and Threshold to Door Frame Sealing.

JOINT ADHESIVE

- CRL RTV408 NEUTRAL CURE SILICONE

NOTE: I.G. butyl contact OK.

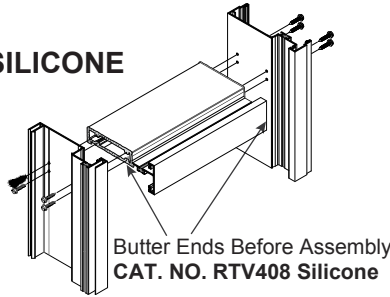

Seal Vertical Gasket Reglet
CAT. NO. RTV408 Silicone

Seal Screw Heads
CAT. NO. RTV408 Silicone

Seal Water Diverter
CAT. NO. RTV408 Silicone

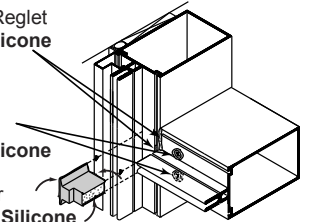

Small Joints, End Joints and Buttered Surfaces, Water Diverters and Reglet Fills.

PERIMETER

- CRL 95C NEUTRAL CURE SILICONE
- CRL M64 (SMOOTH) MODIFIED POLYURETHANE
- CRL M66 (TEXTURED) MODIFIED POLYURETHANE

Exterior Perimeter Caulking
CAT. NO. 95C/M64/M66

Waterproofing Silicone Sealant
CAT. NO. 33S/RTV408

Exterior Perimeter Caulking
CAT. NO. 95C/M64/M66

Do Not Block Weep Holes

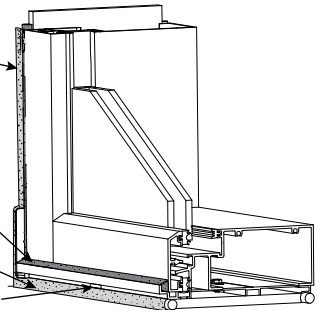

Perimeter Seals, Expansion Joints, Sill and Threshold Beds, Concrete, Wood, and Steel Openings.

EXPANSION

- CRL 95C NEUTRAL CURE SILICONE

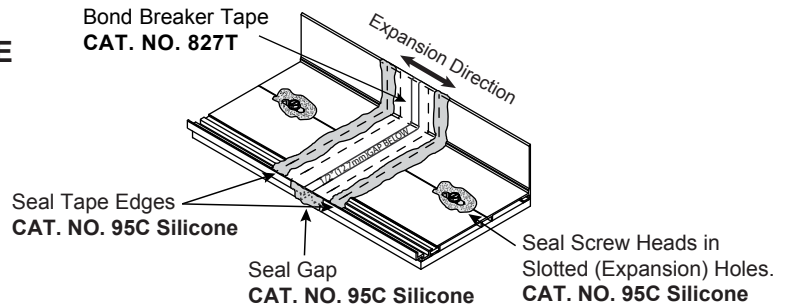

Expansion Joints.

STRUCTURAL

- ALL STRUCTURAL SEALANTS REQUIRE TESTING AND APPROVAL.

Glass-to-Glass or Glass-to-Metal.



JOB SITE ESSENTIALS

Helpful Tools and Supplies for Installing CRL U.S. Aluminum Entrances, Storefronts, Windows, and Curtain Wall Systems



CRL 95C Silicone Building Sealant



CRL RTV408 Neutral Cure Silicone



CRL33S Acetic Cure Silicone Sealant



CRL M64 Smooth Texture Modified Polyurethane Construction Sealant



CRL M66 Grainy Texture Modified Polyurethane Construction Sealant



**CRL12:1 Ratio Strap Frame Caulking Gun
CAT. NO. GA1203**



**CRL Complete Set of Seven All Stainless Steel Spatulas
CAT. NO. AB958G**



CRL Open Cell Backer Rod



**CRL Backer Rod Roller Tool
CAT. NO. SBRR**

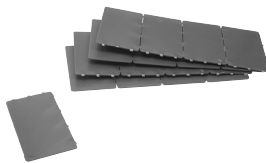

CRL Plastic Bearing Shimstrips



**CRL Soft-Face Power Hitter
CAT. NO. ST57532**

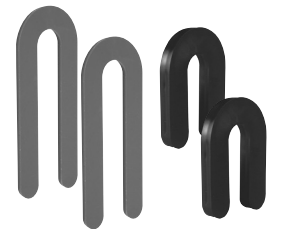

CRL PHS Series Plastic Horseshoe Shims



**CRL Flat Head Phillips Sheet Metal Screws
CAT. NO. 6X1FHPSMS**



**CRL Pan Head Phillips Sheet Metal Screws
CAT. NO. 6X1PHPSMS**



CRL Saint-Gobain/Norton V2100 Thermalbond® Structural Glazing Spacer Tape



**CRL Digital Laser Level Tool
CAT. NO. 406065**